

# TERMINATION FLANGE MOUNT 150 WATT



DATA SHEET

PART SERIES: 32A7187F

SHEET 1 OF 2  
Dwg 32A7187F

EN 13-3517  
Revision-

## FEATURES

- Tab Launch
- High Power
- Integrated Heat Sink
- Low VSWR
- Easy Installation

## APPLICATIONS

- Mobile Networks
- Broadcast
- High Power Amplifiers
- Isolators
- Military
- Instrumentation

## GENERAL DESCRIPTION

EMC Technology offers the widest selection of flange mount terminations worldwide. High power flange components offer excellent performance and the convenience of bolt on installation.

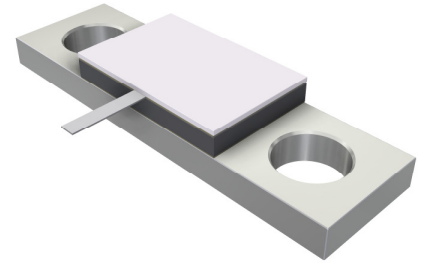

## ORDERING INFORMATION

Part Identifier: **32A7187F**

## SPECIFICATIONS

### 1.0 ELECTRICAL

Nominal Impedance:	50 ohms
Frequency Range:	DC - 3.0 GHz
VSWR:	1.2:1 Max
Input Power CW:	150 Watts @ 100°C heat sink, derated linearly to zero power and 150°C
Peak Power:	1500 Watts (based on 10us pulse width and 1% duty cycle)
DC Resistance:	50 Ω ±5%

### 2.0 ENVIRONMENTAL

Operating Temperature:	-55°C to +150°C
Non-operating Temperature:	-65°C to +150°C
Temperature Coefficient:	+/-200 PPM / °C max

### 3.0 MARKING

Unit Marking:	Logo and Part Number, legibility and permanency per MIL-STD-130
---------------	---

### 4.0 QUALITY ASSURANCE

Visual and Mechanical Inspection:	Per 824W107
DC Resistance Check:	100% DC Resistance Check
Data Retention:	Standard

### 5.0 PACKAGING

Standard Packaging:	Tray Packaging
---------------------	----------------

# TERMINATION FLANGE MOUNT 150 WATT



DATA SHEET

PART SERIES: 32A7187F

SHEET 2 OF 2  
Dwg 32A7187F

EN 13-3517  
Revision-

## 6.0 MECHANICAL

Substrate Material:	Aluminum Nitride
Resistive Film:	Thin Film
Cover Material:	Alumina
Tab Material:	Beryllium Copper
Tab Finish:	Silver
Flange Material:	Copper
Flange Finish:	Nickel
Metric Dimensions:	Provided for reference only

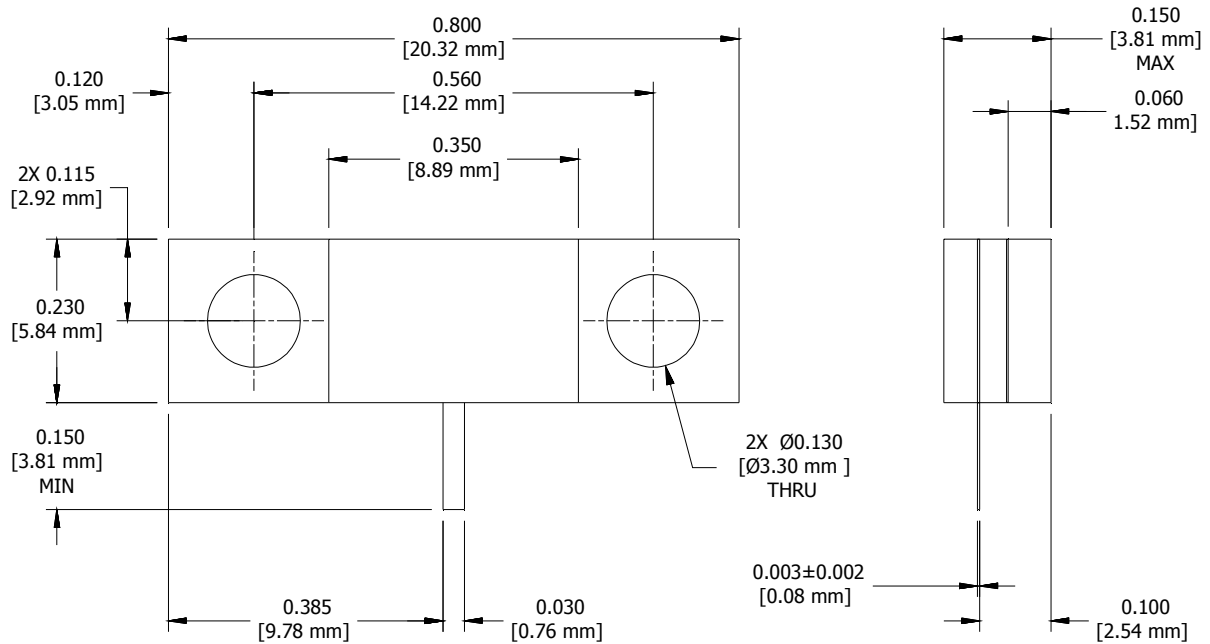
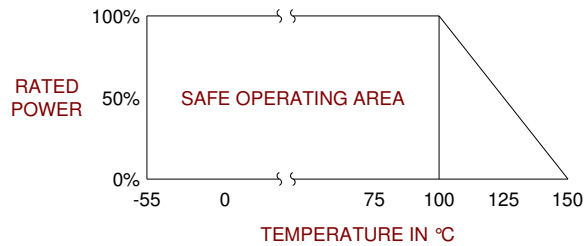

Unless Otherwise Specified: TOLERANCE: X.XX = ± 0.02 X.XXX = ± 0.010