



**TITLE: SPECIFICATION CONTROL DRAWING**

**PART IDENTIFIER:** SMT372503ALN2F

**DESCRIPTION:** SURFACE MOUNT TERMINATION, ALUMINUM NITRIDE, LEAD FREE

**ASSEMBLY DWG:** SMT372503ALN2F

**1.0 SPECIFICATIONS:**

1.1 ELECTRICAL:

1.1.1 IMPEDANCE: 50Ω NOMINAL.

1.1.2 FREQUENCY: DC – 2.2 GHZ.

1.1.3 VSWR: 1.2:1 MAX

1.1.4 INPUT POWER:

1.1.4.1 200 WATTS. CHIP SOLDERED TO MOUNTING SURFACE. MOUNTING SURFACE TEMPERATURE MAINTAINED AT 100°C MAXIMUM. APPLY LINEAR DE-RATING OF INPUT POWER TO 0 WATTS AT 200°C.

1.2 MECHANICAL:

1.2.1 OUTLINE DWG: SEE SHEET 2.

1.2.2 WORKMANSHIP: PER MIL-PRF-55342

1.3 ENVIRONMENTAL:

1.3.1 TEMPERATURE RANGE:

1.3.1.1 NON-OPERATING: -55 °C TO +200 °C.

1.3.1.2 OPERATING: -55 °C TO +200 °C.

**2.0 UNIT MARKING:** NONE.

**3.0 QUALITY ASSURANCE:**

3.1 SAMPLE INSPECT PER ANSI/ASQC Z1.4 GENERAL INSPECTION, LEVEL II, AQL = 1.0.

3.1.1 VISUAL AND MECHANICAL PER 824W154.

3.1.2 DC RESISTANCE: 50Ω ± 2%.

3.2 DATA REQUIREMENTS:

3.2.1 NO TEST DATA REQUIRED FOR CUSTOMER.

3.2.2 DATA RETENTION – 24 MONTHS.

**4.0 PACKAGING:** STANDARD PACK PER 755W002.

<b>EMC TECHNOLOGY</b> 8851 SW OLD KANSAS AVE. STUART, FL 34997	<b>CAGE CODE # 24602</b>		<b>DWG #</b>	SMT372503ALN2F	
	<b>CHANGE NOTICE</b>	EN 10-1334	<b>REV LVL</b>	-	
			<b>SHEET</b>	1 OF 2	

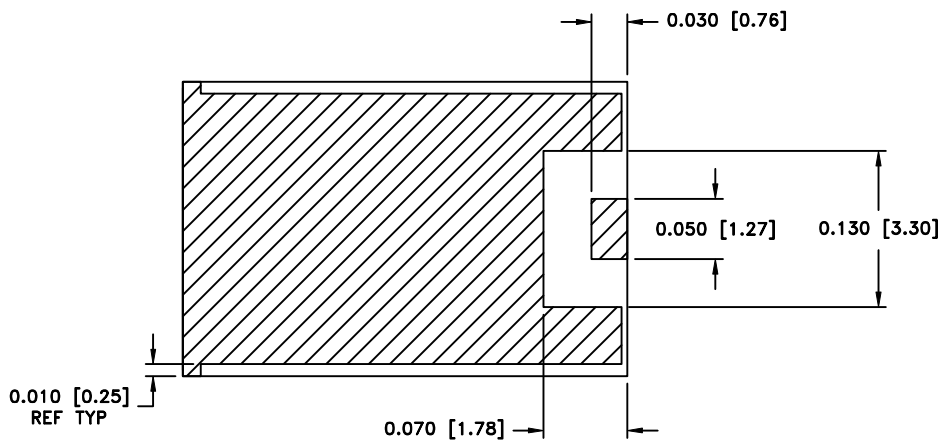
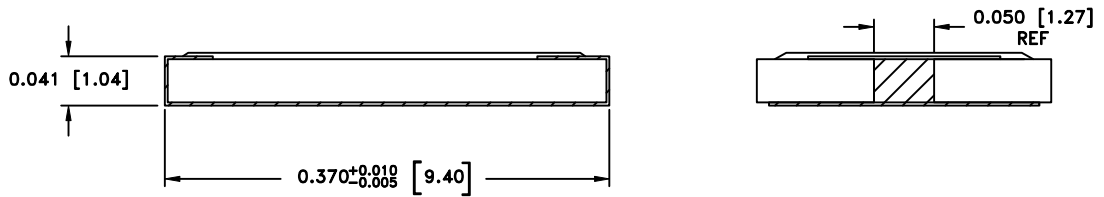
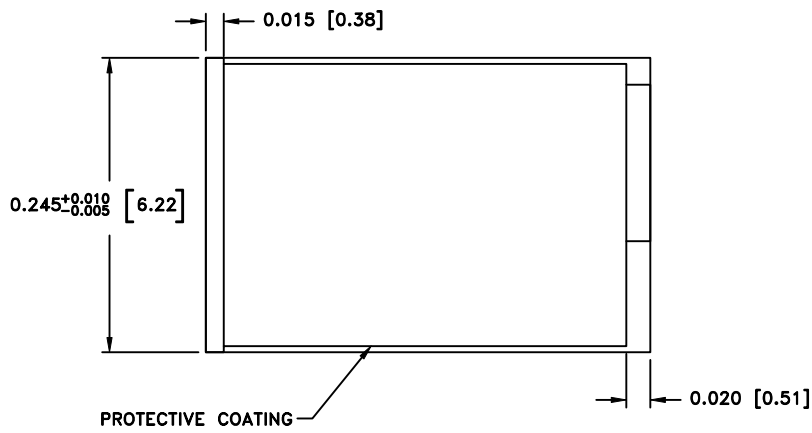

**MECHANICAL SPECIFICATIONS**

SUBSTRATE:  
 MATERIAL - ALUMINUM NITRIDE, MIL-I-10.  
 TERMINALS:  
 MATERIAL - THICK FILM, LEAD FREE PLATING.  
 ROHS COMPLIANT.  
 RESIST:  
 MATERIAL - THICK FILM.

METRIC EQUIVALENTS GIVEN IN [mm]  
 ARE FOR REFERENCE INFORMATION ONLY

**POWER RATING AND DERATING**

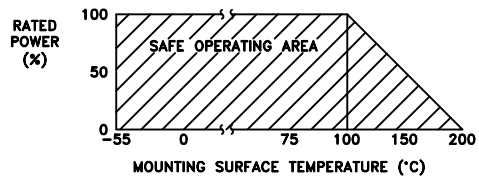

8851 SW OLD KANSAS AVE  
 STUART, FL 34997  
 PHONE NO. (772)286-9300  
 FAX NO. (772)283-5286

UNLESS OTHERWISE SPECIFIED DIMENSIONS ARE IN INCHES  
**TOLERANCES**  
 FRACT ---  
 ANG ---  
 XX ---  
 XXX ±0.005  
 XXXX ---

THESE DRAWINGS AND SPECIFICATIONS ARE THE PROPERTY OF EMC TECHNOLOGY INC AND SHALL NOT BE DUPLICATED OR USED AS BASIS FOR THE MANUFACTURE OR SALE OF PARTS OR DEVICES WITHOUT PERMISSION.

CAGE CODE	SCALE	DRAWN BY	CHECKED BY	APPROVED BY
24602	10:1	JG 11/22/10		
REV	CHANGE NOTICE	DRAWING NO	SHEET	
-	EN 10-1334	SMT372503ALN2F	2 OF 2	