

NEBULA CONNECTOR SERIES

High Reliability SATA Connectors



HYPERBOLOID TECHNOLOGY

Smiths Connectors offers an extensive range of superior contact technologies suitable for standard and custom solutions. Hypertac® (HYPERboloid conTACT) is the original superior performing hyperboloid contact technology designed for use in all applications and in harsh and demanding environments where high reliability and safety are critical. The inherent electrical and mechanical characteristics of the Hypertac hyperboloid contact ensures unrivalled performance in terms of reliability, number of mating cycles, low contact force and minimal contact resistance. The shape of the contact sleeve is formed by hyperbolically arranged contact wires, which align themselves elastically as contact lines around the pin, providing a number of linear contact paths.

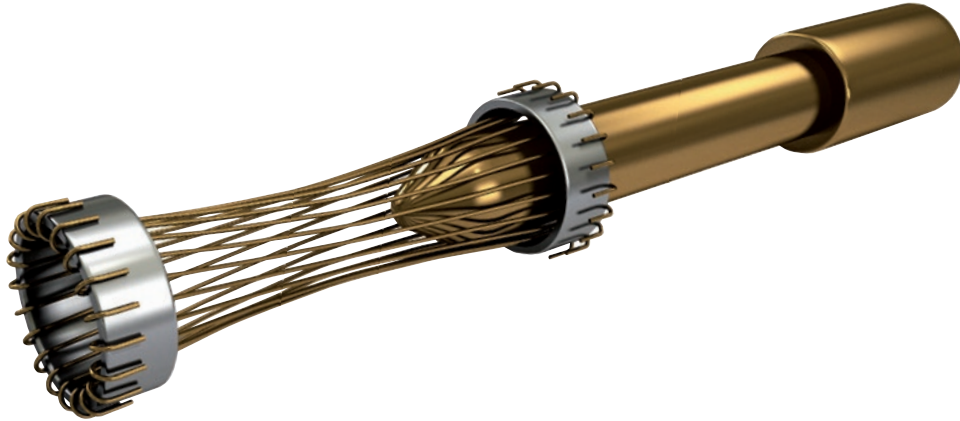

FEATURES

LOW INSERTION/EXTRACTION FORCES

The angle of the socket wires allows tight control of the pin insertion and extraction forces. The spring wires are smoothly deflected to make line contact with the pin.

LONG CONTACT LIFE

The smooth and light wiping action minimizes wear on the contact surfaces. Contacts perform up to 100,000 insertion/extraction cycles with minimal degradation in performance.

LOWER CONTACT RESISTANCE

The design provides a far greater contact area and the wiping action of the wires ensures a clean and polished contact surface. Our contact technology has half the resistance of conventional contact designs.

HIGHER CURRENT RATINGS

The design parameters of the contact (e.g., the number, diameter and angle of the wires) may be modified for any requirement. The number of wires can be increased so the contact area is distributed over a larger surface. Thus, the high current carried by each wire because of its intimate line contact, can be multiplied many times.

IMMUNITY TO SHOCK & VIBRATION

The low mass and resultant low inertia of the wires enable them to follow the most abrupt or extreme excursions of the pin without loss of contact. The contact area extends 360 degrees around the pin and is uniform over its entire length. The 3 dimensional symmetry of the Hypertac contact design guarantees electrical continuity in all circumstances.

BENEFITS

HIGH DENSITY INTERCONNECT SYSTEMS

Significant reductions in size and weight of sub-system designs. No additional hardware is required to overcome mating and un-mating forces.

LOW COST OF OWNERSHIP

The Hypertac contact technology will surpass most product requirements, thus eliminating the burden and cost of having to replace the connector or the entire subsystem.

LOW POWER CONSUMPTION

The lower contact resistance of our technology results in a lower voltage drop across the connector reducing the power consumption and heat generation within the system.

MAXIMUM CONTACT PERFORMANCE

The lower contact resistance of the Hypertac contact reduces heat build-up; therefore Hypertac contacts are able to handle far greater current in smaller contact assemblies without the detrimental effects of high temperature.

RELIABILITY UNDER HARSH ENVIRONMENTS

Harsh environmental conditions require connectors that will sustain their electrical integrity even under the most demanding conditions such as shock and vibration. The Hypertac contact provides unmatched stability in demanding environments when failure is not an option.

FEATURES

- ▶ Utilizes field proven Hypertac® contact technology
 - ▶ Wire basket design with 360° of contacts
 - ▶ 50% lower contact resistance than conventional contacts
- ▶ Meets mechanical footprint of standard COTS SATA device connectors
- ▶ Optional quarter-turn locking feature available
- ▶ Straddle, vertical PCB and right angle PCB production products currently available
- ▶ All materials pass NASA outgassing requirements
- ▶ Rugged mechanical design including 50 µin of gold plating on all mating surfaces

BENEFITS

- ▶ High speed design
 - ▶ Superior signal integrity beyond 6 Gbps which exceeds the data rate requirements for the SATA standard
 - ▶ Highly optimised connector design for high speed data rates, impedance matching and minimal losses
- ▶ Long contact life
 - ▶ Contacts perform up to 100,000 insertion/extraction cycles with minimal degradation in performance
- ▶ Extreme rugged performance
 - ▶ Immunity to shock and vibration fretting
 - ▶ 30 g of vibration (5 hrs. per axis)
 - ▶ 100 g of shock (6 shocks per axis)

NEBULA SERIES

The Nebula Series by Smiths Connectors is a high reliability SATA 6.0 Gbps connector line designed for harsh environment and rugged storage applications within the aerospace, defence and industrial market segments. Used to transmit and receive critical data, the Nebula Connector Series provide the absolute reliability required by mass storage devices to ensure maximum transfer speed under the most extreme conditions. Standard SATA connectors were originally designed to meet the requirements of HDD (Hard Disk Drives) but are not durable enough to survive the capabilities of today's SSD (Solid State Drives) which are now being used more and more in remote and harsh environments.

Nebula Connector Series employ Hypertac® contacts as the foundation of its reliability which offer up to 100,000 mating cycles, immunity to shock and vibration fretting, current carrying capacity up to 1.5 Amps per contact and low insertion / extraction forces; eliminating the quality and reliability issues associated with commodity connector solutions. Further, the pins and sockets are protected by recessed contacts within insulators which are made from rugged, heavy duty polymers that prevent cracking in extreme environments.

Smiths Connectors suite of products and services provides proven industry leading performance and unequalled reliability for heavy use, data storage applications such as rugged SSD storage solutions. Eliminate the weak link in your rugged data storage solution with the Smiths Connectors' Nebula Series connector line.



TECHNICAL CHARACTERISTICS

Contact Diameter	0.016" (0.4 mm)
Pitch	0.05" (1.27 mm)

MECHANICAL & ENVIRONMENTAL

Contact Resistance	< 8 mΩ (per contact)
Insertion/Extraction Force	3 lbs. max./2.5 lbs. max
Connector Life Cycle	> 5,000
Temperature Rating	-55° C to 125° C
Shock	100 g, 11 ms, half sine, 6 shocks per axis
Vibration	EIA 364-28, condition V test letter A, 30 g (3 axis, 5 hrs per axis)

MATERIALS & FINISHES

Insulator	LCP
Pin	Beryllium copper 50 μin gold over nickel on mating surface, 5 μin gold over nickel on solder tails
Sockets	Brass bodies with beryllium copper contact wires 50 μin gold over nickel on mating surface, 5 μin gold over nickel on solder tails

ELECTRICAL

Current Rating	1.5 A per contact
DWV	> 500V
Data Rate	> 6.0 Gbps

DIMENSIONS

Product Drawings & PCB Layouts

► STRADDLE MOUNT CONNECTOR (DEVICE)

Product P/N: KSD22-SMT00H1TAH

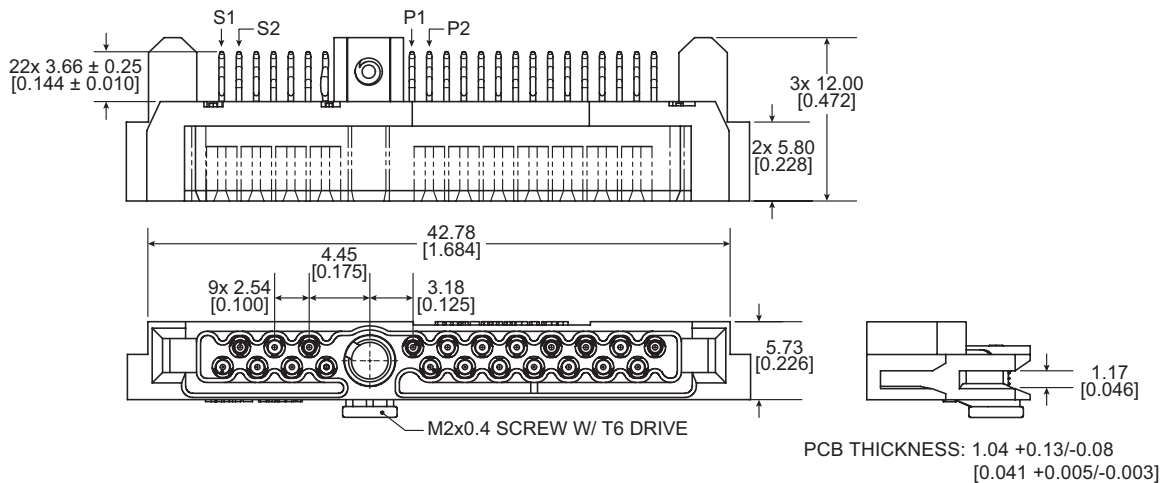
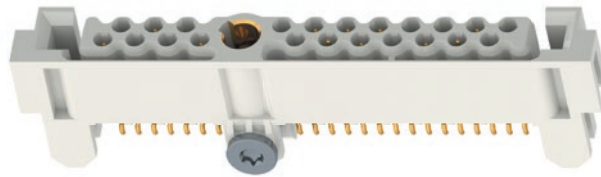

PCB LAYOUT

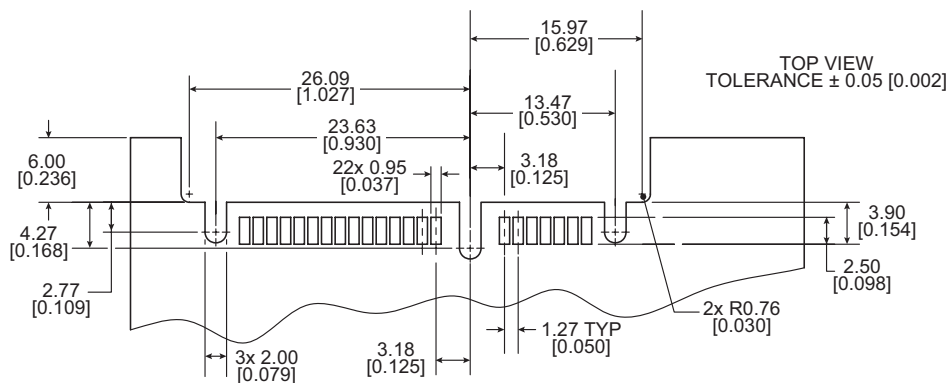

Notes:
1) Dimensions are in mm [inches]

► VERTICAL CONNECTOR

Product P/N: KSD22-VFD04H0TAH

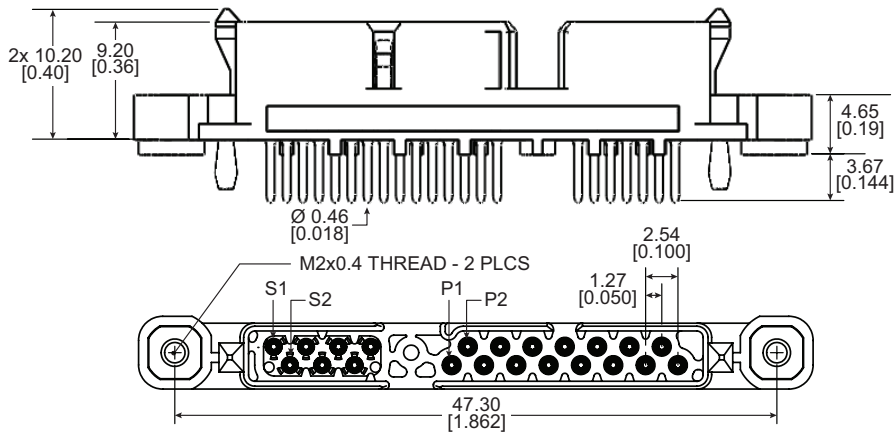
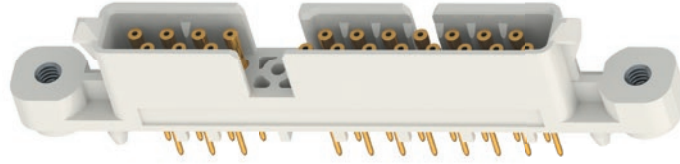

PCB LAYOUT

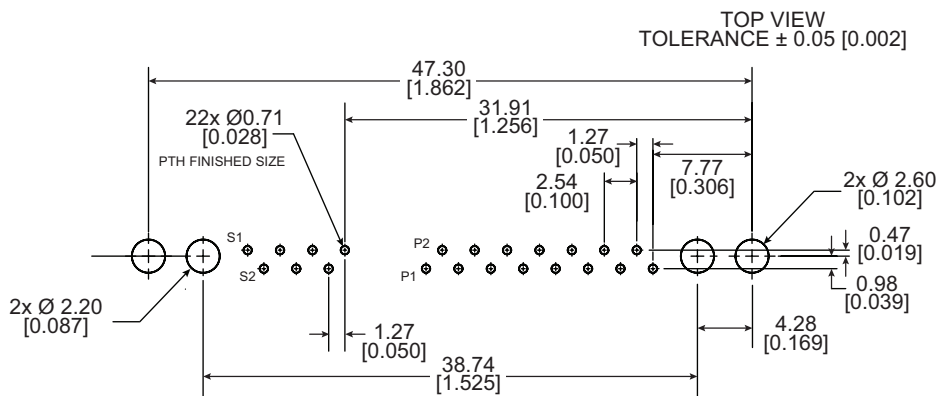

► **RIGHT ANGLE CONNECTOR**

Product P/N: KSD22-RFD08H0TAH

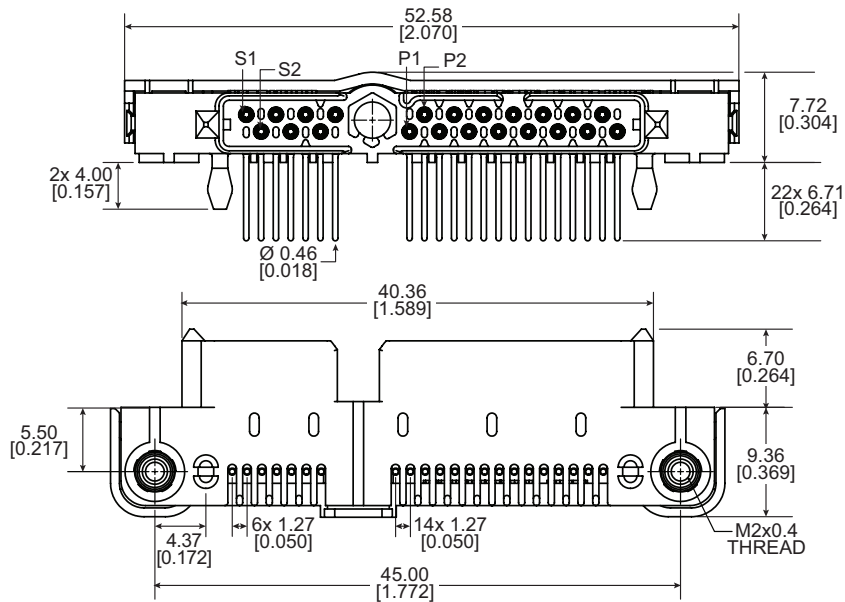
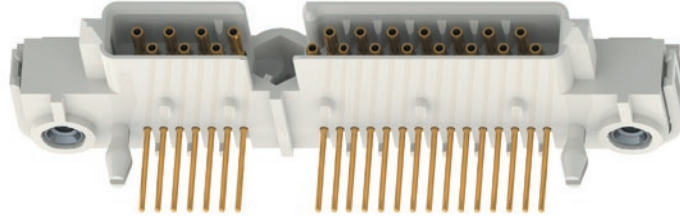

PCB LAYOUT

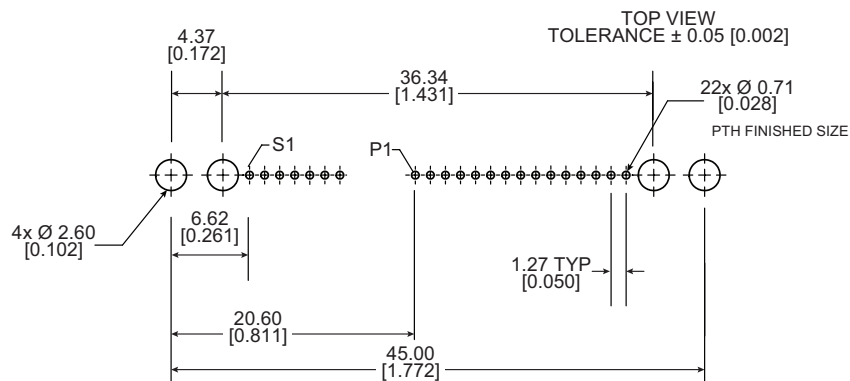

Notes:
1) Dimensions are in mm [inches]

HOW TO ORDER

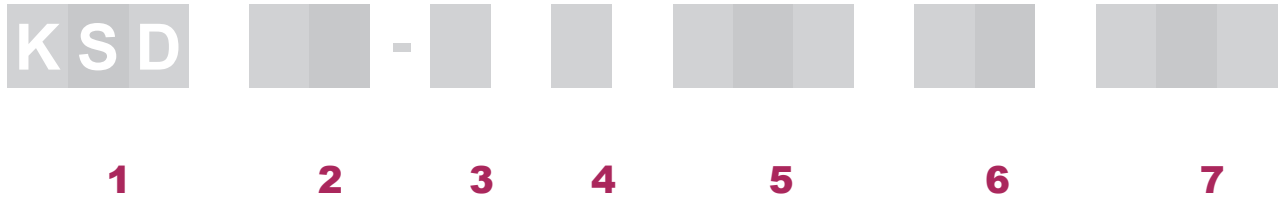
**1** ▶ **CONNECTOR SERIES** *(Fixed)***KSD** NEBULA CONNECTOR SERIES**2** ▶ **NUMBER OF CONTACTS****22** CONTACTS**3** ▶ **APPLICATION TYPE****S** STRADDLE MOUNT **V** VERTICAL**R** RIGHT ANGLE**4** ▶ **INSULATOR****M** PLUG *(male)* **F** RECEPTACLE *(female)***5** ▶ **TERMINATION STYLE****T00** STRADDLE MOUNT**D02** SOLDER TAIL 0.063" (1.60 mm) PCB THICKNESS⁽¹⁾**D03** SOLDER TAIL 0.096" (2.44 mm) PCB THICKNESS⁽¹⁾**D04** SOLDER TAIL 0.125" (3.18 mm) PCB**D08** SOLDER TAIL 0.250" (6.35 mm) PCB**6** ▶ **LOCKING HARDWARE****H0** NO LOCKING HARDWARE**H1** QUARTER TURN FEMALE HARDWARE *(straddle)***H2** QUARTER TURN MALE HARDWARE *(right angle)***7** ▶ **CONTACT PLATING****TAH** 50 µin GOLD ON THE CONTACT MATING SURFACE

Notes:

1) Contact factory for availability