

K CONNECTOR SERIES

Medium & High Density PCB Connectors

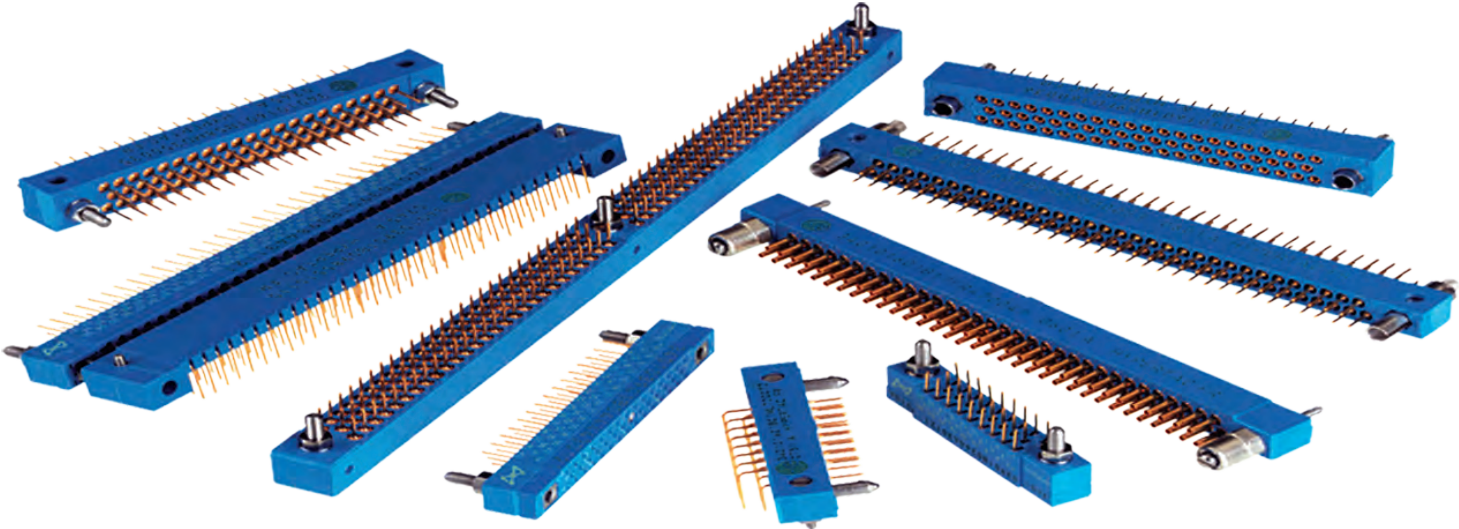

HYPERBOLOID TECHNOLOGY

Smiths Connectors offers an extensive range of superior contact technologies suitable for standard and custom solutions. Hypertac® (HYPERboloid conTACT) is the original superior performing hyperboloid contact technology designed for use in all applications and in harsh and demanding environments where high reliability and safety are critical. The inherent electrical and mechanical characteristics of the Hypertac hyperboloid contact ensures unrivalled performance in terms of reliability, number of mating cycles, low contact force and minimal contact resistance. The shape of the contact sleeve is formed by hyperbolically arranged contact wires, which align themselves elastically as contact lines around the pin, providing a number of linear contact paths.

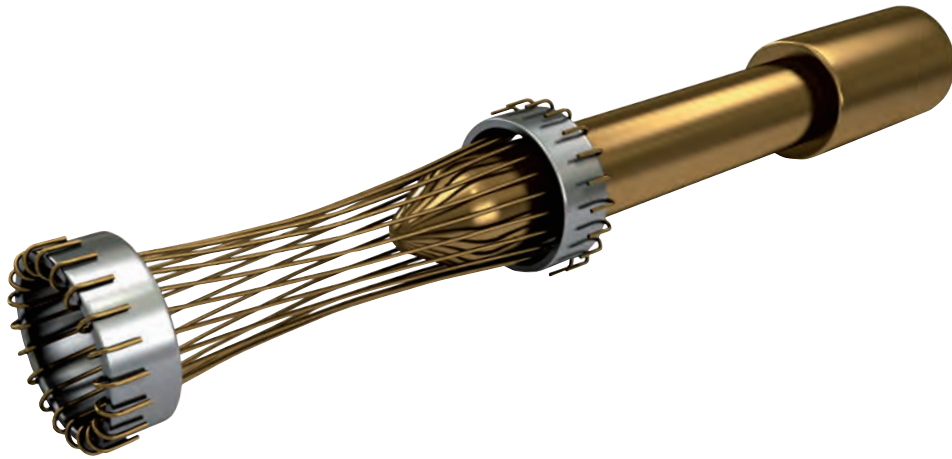

FEATURE

LOW INSERTION/EXTRACTION FORCES

The angle of the socket wires allows tight control of the pin insertion and extraction forces. The spring wires are smoothly deflected to make line contact with the pin.

LONG CONTACT LIFE

The smooth and light wiping action minimizes wear on the contact surfaces. Contacts perform up to 100,000 insertion/extraction cycles with minimal degradation in performance.

LOWER CONTACT RESISTANCE

The design provides a far greater contact area and the wiping action of the wires insures a clean and polished contact surface. Our contact technology has about half the resistance of conventional contact designs.

HIGHER CURRENT RATINGS

The design parameters of the contact (e.g., the number, diameter and angle of the wires) may be modified for any requirement. The number of wires can be increased so the contact area is distributed over a larger surface. Thus, the high current carried by each wire because of its intimate line contact, can be multiplied many times.

IMMUNITY TO SHOCK & VIBRATION

The low mass and resultant low inertia of the wires enable them to follow the most abrupt or extreme excursions of the pin without loss of contact. The contact area extends 360° around the pin and is uniform over its entire length. The 3 dimensional symmetry of the Hypertac contact design guarantees electrical continuity in all circumstances.

BENEFIT

HIGH DENSITY INTERCONNECT SYSTEMS

Significant reductions in size and weight of sub-system designs. No additional hardware is required to overcome mating and un-mating forces.

LOW COST OF OWNERSHIP

The Hypertac contact technology will surpass most product requirements, thus eliminating the burden and cost of having to replace the connector or the entire subsystem.

LOW POWER CONSUMPTION

The lower contact resistance of our technology results in a lower voltage drop across the connector reducing the power consumption and heat generation within the system.

MAXIMUM CONTACT PERFORMANCE

The lower contact resistance of the Hypertac contact reduces heat build-up; therefore Hypertac contacts are able to handle far greater current in smaller contact assemblies without the detrimental effects of high temperature.

RELIABILITY UNDER HARSH ENVIRONMENTS

Harsh environmental conditions require connectors that will sustain their electrical integrity even under the most demanding conditions such as shock and vibration. The Hypertac contact provides unmatched stability in demanding environments when failure is not an option.

TABLE OF CONTENTS

KN SERIES - Medium Density PCB Connectors

- ▶ KNB series (2 rows)2
- ▶ KXB series (2 rows)19
- ▶ KNC/KND series (3 rows)22
- ▶ Contacts.....38
- ▶ Accessories and tools39

KM SERIES - High Density PCB Connectors

- ▶ KMC Series (3 rows).....42
- ▶ KMH Series (3 rows).....65
- ▶ Accessories and tools71

TECHNICAL CHARACTERISTICS

Contact diameter	HYPERTAC® type Ø 0.60 mm rear removable
Number of contact	Up to 120
Pitch	2.54mm between rows 1.27mm between quicuncial contacts
Rows	2

MATERIALS & PLATINGS

Contact	Brass or bronze
Moulding	Glass fiber filled diallyl - Phtalate
Guides	Stainless steel or nickel plated brass

	Standard	ESA
Pin body	0.25 µm Gold / 1.27 µm Ni	1.27 µm Gold / 1.27 µm Ni (min)
Socket body	0.25 µm Gold / 1.27 µm Ni on activ area 1.27 µm Ni on non activ area	0.25 µm Gold / 1.27 µm Ni (min)
Socket wires	1 µm Gold / 0.20 µm Ni	1.27 µm Gold / 0.20 µm Ni (min)

ELECTRICAL

Current rating (at 25°C)	Standard: 3 A max ESA: 5 A max
Dielectric withstanding voltage	1200 Vrms
Contact resistance	≤ 8 mΩ
Insulation resistance	> 10 ⁴ mΩ (500 Vcc)

MECHANICAL

Mating & unmating cycle	5000
Guiding	By two outside guides (2 guiding styles) and one central guide (3 guiding styles)
Keying	By rotating of outside polarised guides (up to 36 keying)

ENVIRONMENTAL

Temperature range	-55° C + 125° C
Conformity	MIL C 55302, ESA/ESCC3401/016 - 3401/017, NF C-UTE C 93-424

Dimension are in mm

HOW TO ORDER



1 ▸ SERIES

2 ▸ PITCH OR TYPE N 1.27 MM PITCH, REAR REMOVABLE CONTACTS

3 ▸ MODEL B 2 ROWS

4 ▸ NUMBER OF CONTACTS

0 1 7 0 2 9 0 4 1 0 5 3 0 6 5 0 7 2 0 8 4 0 9 6 1 2 0

For the right angle 053 layout, KNB must be replaced by KXB - (details on page 20)

7 ▸ MOULDING POLARITY

NF C-UTE C 93-424 **MIL-C-55302** **ESA/ESCC 3401/01601B** **SPACE GRADE**

12	14	54	54	Female plug	1A	1C	-	5A	Tinned female plug**	26	28	-	46	Tinned female receptacle*
13	15	55	55	Male plug	1B	1D	-	5B	Tinned male plug**	27	29	-	47	Tinned male receptacle*
16	18	-	56	Tinned female plug*	22	24	44	44	Female receptacle	2A	2C	-	-	Tinned female receptacle**
17	19	-	57	Tinned male plug*	23	25	45	45	Male receptacle	2B	2D	-	-	Tinned male receptacle**

6 ▸ TERMINATION STYLES

1 0 Through board solder - 90° - length 3 mm	2 1 Double crimp	5 1 Wire wrap (3 wrapping levels)
1 1 Through board solder - 90° - length 4 mm	3 0 Through board solder - straight	9 1 Female - male
2 0 Crimp	4 0 Solder bucket	

7 ▸ MOUNTING HARDWARE

GUIDE STYLES (consult us for special guides)

1 10 Male polarised, transverse mount, standard plug	1 45 Male polarised, transverse mount on receptacle only	1 31 Male unpolarised, transverse mount
1 11 Male polarised, vertical mount	1 90 Female power or mass contact, vertical mount	1 32 Female unpolarised, transverse mount
1 13 Male polarised, float mount	1 25 Male unpolarised, transverse mount	1 33 Female all polarised, transverse mount
1 21 Female polarised, vertical mount	1 26 Female unpolarised, vertical mount	1 91 Male power or mass contact, vertical mount
1 23 Female polarised, float mount	1 27 Male unpolarised, vertical mount	
1 24 Female polarised, transverse mount	1 30 Female unpolarised, vertical mount	

LOCKING STYLES

MALE PLUG		FEMALE RECEPTACLE	
2 0 1	1/4 turn, free connector	2 0 2	1/4 turn, vertical mount
2 0 3	1/4 turn, transverse mount	2 0 4	1/4 turn, transverse mount
2 0 7	Jack screw, free connector	2 0 8	Jack screw, transverse mount
2 1 1	Jack screw, free connector	2 1 0	Jack screw, free connector
2 9 0	Jack screw, vertical mount	2 1 2	Jack screw, transverse mount
		2 1 5	Jack screw, vertical mount
		2 1 9	Jack screw, vertical mount
		2 3 2	Jack screw, with operation button

* For 90° & straight terminations (splicing on PCB)

** RoHS compliant for 90° & straight terminations (splicing on PCB)

HYPERTAC & ESA CORRESPONDANCE TABLE

HYPERTAC

KNB

34 01 016 01 B

1

2

3

4

5

6

1 ▶ ESCC COMPONENT NUMBER

2 ▶ MOUNTING

HYPERTAC

ESA

Plug KNB 017	01	Plug KNB 096	08	Receptacle KNB 053	16	Plug KNB 072	56	Plug KNC 098	62
Plug KNB 029	02	Plug KNB 120	10	Receptacle KNB 065	17	Receptacle KNB 072	57	Receptacle KNC 098	63
Plug KNB 041	03	Plug KNC 160	12	Receptacle KNB 084	19	Plug KNC 062	58		
Plug KNB 053	04	Receptacle KNB 017	13	Receptacle KNB 096	20	Receptacle KNC 062	59		
Plug KNB 065	05	Receptacle KNB 029	14	Receptacle KNB 120	22	Plug KNC 080	60		
Plug KNB 084	07	Receptacle KNB 041	15	Receptacle KNC 160	24	Receptacle KNC 080	61		

REMINDER SPATIAL P.P.P. (Party Polarity Protection)

Female receptacle	44
Male receptacle	45

Plug female	54
Plug male	55

EXAMPLE

KNB 029 **44** 40 113
P.P.P.

3 ▶ TERMINATION STYLE

HYPERTAC

ESA

Bent male 10	MC	Solder bucket male 40	MS	Crimp female 20	FR	Female-male 91	FM
Bent long male 11	ML	Mini-wrapping male 51	MY	Straight female 30	FD		
Crimp male 20	MR	Bent female 10	FC	Solder bucket female 40	FS		
Straight male 30	MD	Bent long female 11	FL	Mini-wrapping female 51	FY		

4 ▶ LOCKING TYPE - ON LEFT SIDE

HYPERTAC

ESA

Guideless connector	00	KNB 10 110	33	KN 232	45	KNB 212	52	KNC 124	74
KNB 10 125	26	KNC 10 110	34	KN 231	46	KN 215	53	KNC 132	75
KNC 10 125	27	KN 111	35	KN 207	47	KN 123	54	KNC 11 110	76
KN 127	28	KN 121	36	KNB 10 208	48	KN 113	55	KNC 11 125	77
KN 126	29	KNB 145	40	KNC 10 209	49	KNB 11 125	71	KNB 11 208	79
KNB 131	31	KNB 124	41	KN 210	50	KNB 11 110	72	KN 219	80
KNB 132	32	KNC 10 230	43	KN 211	51	KNB 10 230	73	KN 290*	81

5 ▶ LOCKING TYPE - IN CENTER

00 FOR 2 GUIDE CONNECTORS

- - FOR 3 GUIDE CONNECTORS (see table 4, LOCKING TYPE - ON LEFT SIDE)

6 ▶ LOCKING TYPE - ON RIGHT SIDE

(see table 4, LOCKING TYPE - ON LEFT SIDE)

* Please consult us

CONTACT TERMINATIONS

PLUG

RECEPTACLE

MALE

FEMALE

FEMALE

MALE

90° THROUGH BOARD SOLDER

Ref: **10** (X=3) Ref : **MC & FC** - Ref: **11** (X=4) Ref : **ML & FL**

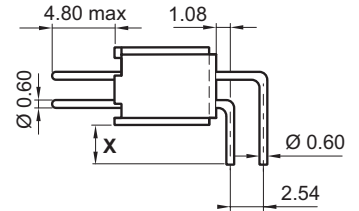
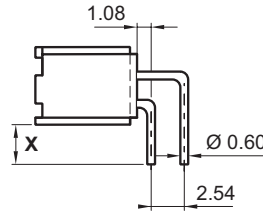
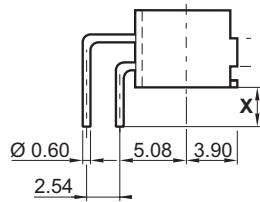
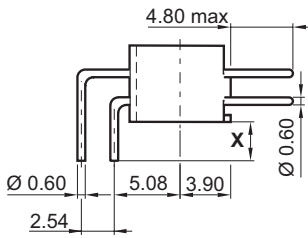

CRIMP (AWG 28-26 & 24-22)

Ref: **20** Ref : **MR & FR**

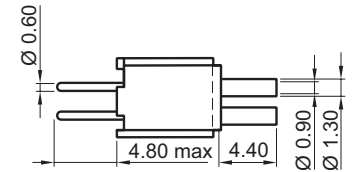
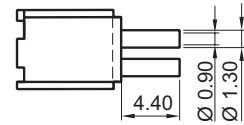
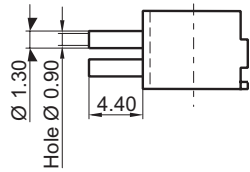
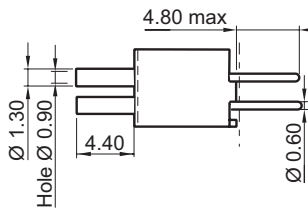

CRIMP (AWG 28-26 & 24-22) & CRIMP ON SHEATH (Ø 1.45)

Ref: **21**

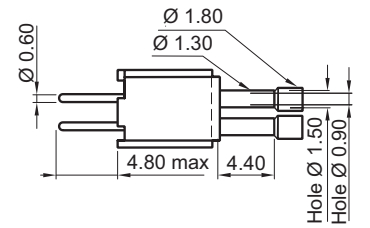
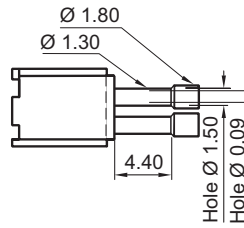
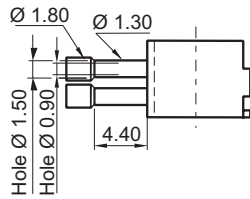
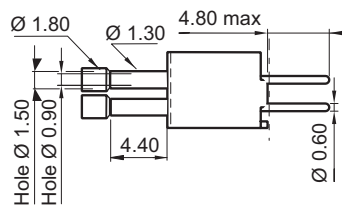

STRAIGHT THROUGH BOARD SOLDER

Ref: **30** (X=4.50) Ref : **MD & FD** Ref **31** (5.60)

See: 90° Through board solder

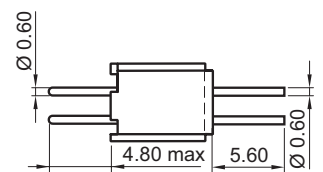
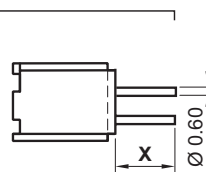
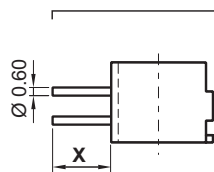
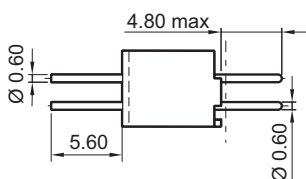

▶ CONTACT TERMINATIONS

PLUG

RECEPTACLE

MALE

FEMALE

FEMALE

MALE

SOLDER BUCKET (AWG 22 max)

Ref: 40 Ref : MS & FS

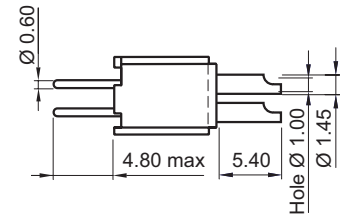
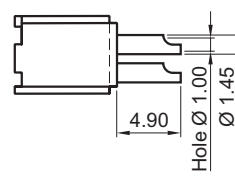
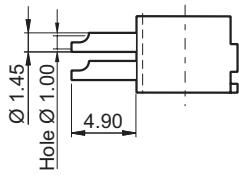
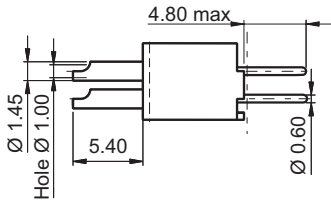

WIRE WRAP (3 wrapping levels)

Ref: 51 Ref : MY & FY

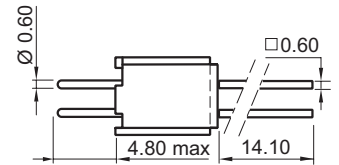
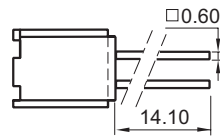
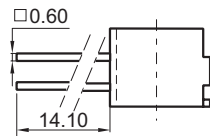
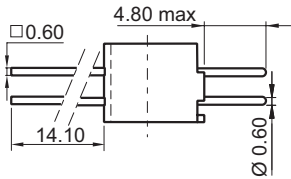

SAVER (male-male)

Ref: 90

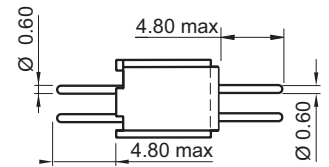
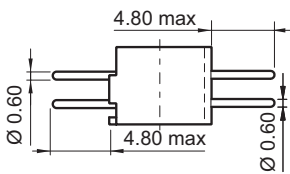

SAVER (female-male)

Ref: 91 Ref : FM

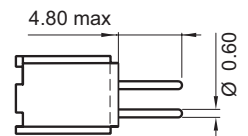
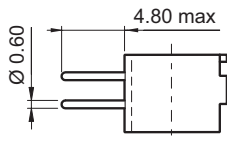

CONNECTOR DIMENSIONS

PLUG

RECEPTACLE

17 TO 65 CONTACTS

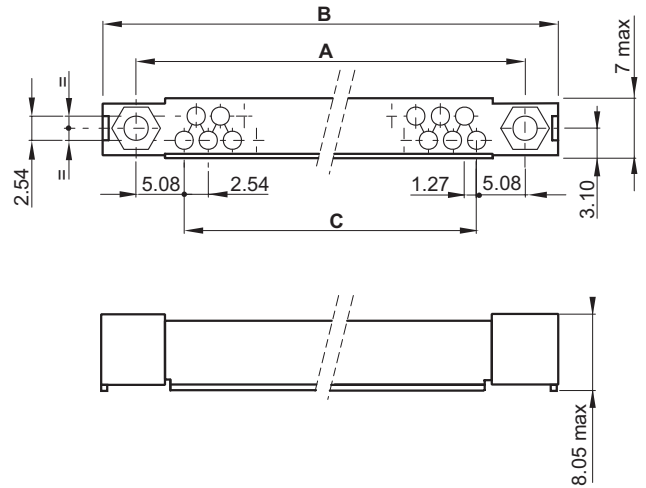
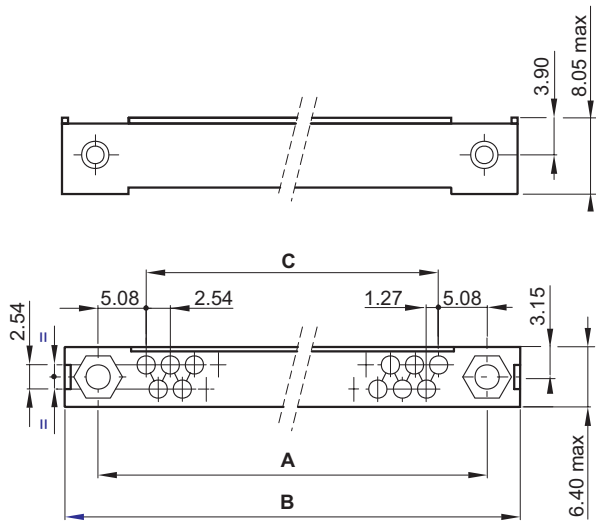

72 TO 120 CONTACTS

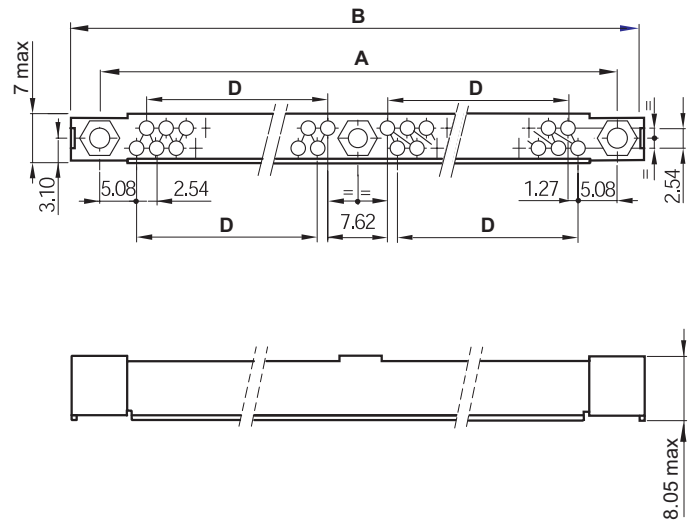
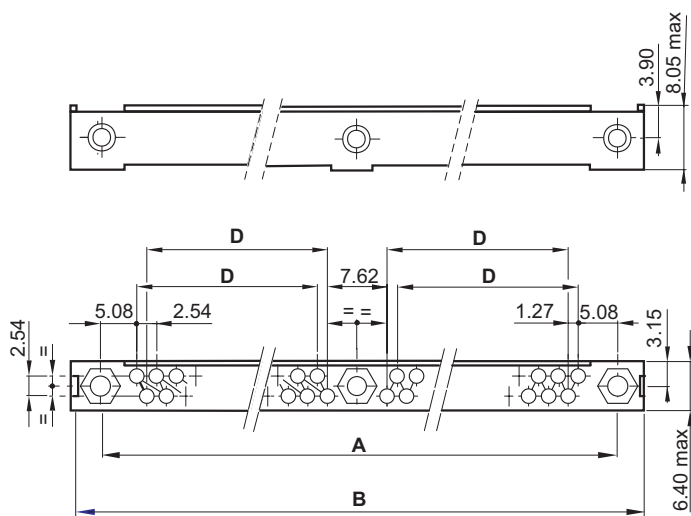

No. of contacts	17	29	41	53	65	72	84	96	120
A	30.48	45.72	60.96	76.20	91.44	106.68	121.92	137.16	167.64
B max	38.50	53.70	69.00	84.20	99.50	114.70	129.90	145.20	175.50
C	20.32	35.56	50.80	66.04	81.28	-	-	-	-
D	-	-	-	-	-	43.18	50.80	58.42	73.66

MR 23	FR 22	FP 12	MP 13	MR 23	FR 22	FP 12	MP 13	MR 23	FR 22	FP 12	MP 13	MR 23	FR 22	FP 12	MP 13	Polarity		
																Receptacle	Moulding	
																Plug	Moulding	
																90°	10	11
																Straight	30	31
																Solder bucket	Contact	
																Crimp	20	21
																Wire wrap	Contact	
																	51	

MR 23	FR 22	FP 12	MP 13	MR 23	FR 22	FP 12	MP 13	MR 23	FR 22	FP 12	MP 13	MR 23	FR 22	FP 12	MP 13				
																			191
																			145
																			131
																			127
																			125
																			113
																			111
																			110

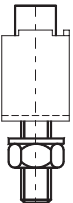
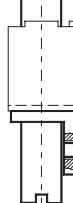
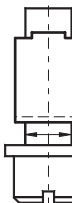
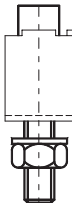
			
126	124	123	121

Male guides	
Female guides	

Guiding devices

► GUIDE STYLES

PLUG & RECEPTACLE

MALE

POLARISED VERTICAL MOUNT

Ref: 111 Ref ©: 35

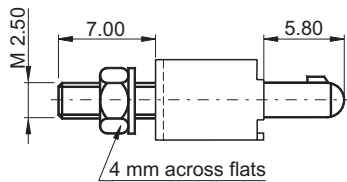

FEMALE

POLARISED VERTICAL MOUNT

Ref: 121 Ref ©: 36

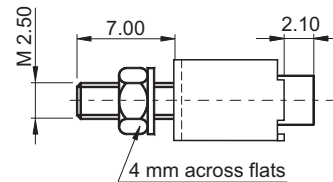

POLARISED VERTICAL FLOAT MOUNT

Ref: 113 Ref ©: 55

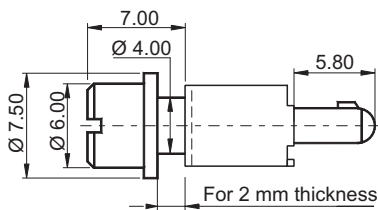

POLARISED VERTICAL FLOAT MOUNT

Ref: 123 Ref ©: 54

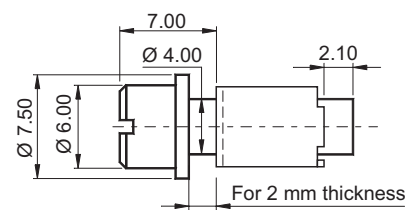

UNPOLARISED VERTICAL MOUNT

Ref: 127 Ref ©: 28

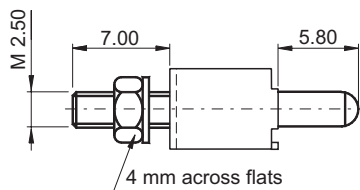

POLARISED TRANSVERSE MOUNT

Ref: 124 Ref ©: 41

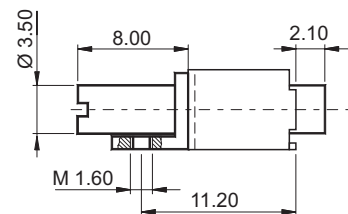

UNPOLARISED TRANSVERSE MOUNT

Ref: 131 Ref ©: 31

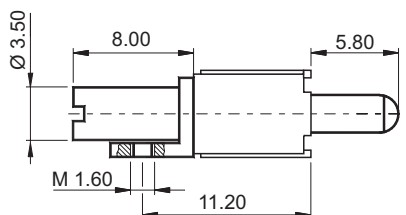

UNPOLARISED VERTICAL MOUNT

Ref: 126 Ref ©: 29

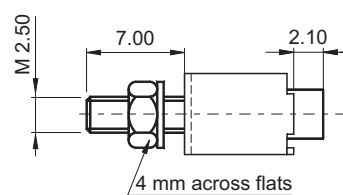

► GUIDE STYLES

PLUG & RECEPTACLE

MALE

POLARISED TRANSVERSE MOUNT

Ref: 145 Ref : 40

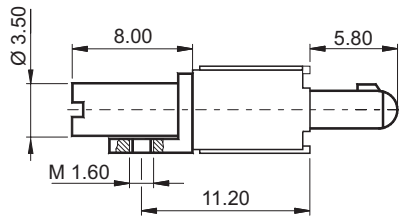

FEMALE

ALL POLARISED VERTICAL MOUNT

Ref: 130

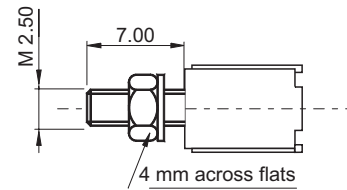

UNPOLARISED TRANSVERSE MOUNT

Ref: 132 Ref : 32

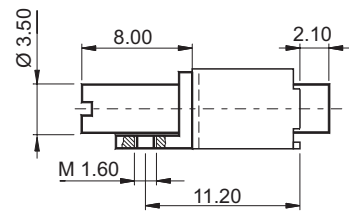

ALL POLARISED TRANSVERSE MOUNT

Ref: 133

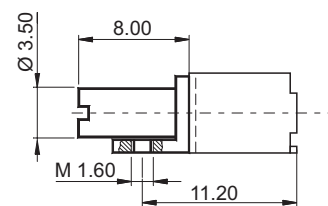

▶ GUIDE STYLES

PLUG & RECEPTACLE

MALE

POWER OR MASS TRANSVERSE MOUNT

Ref: **191**

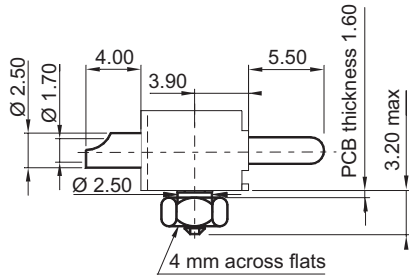

FEMALE

POWER OR MASS VERTICAL MOUNT

Ref: **190**

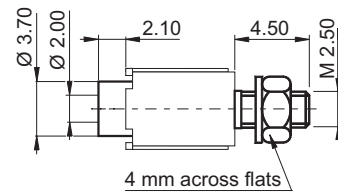

MALE PLUG ONLY

POLARISED TRANSVERSE MOUNT

Ref: **10 110** Ref: **33** X=1.60 Y=3.20
 Ref: **11 110** Ref: **72** X=2.40 Y=4.90

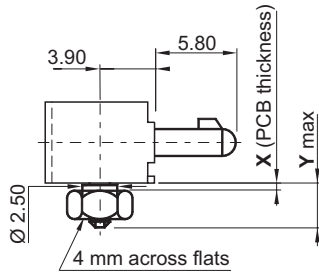

UNPOLARISED TRANSVERSE MOUNT

Ref: **10 125** Ref: **26** X=1.60 Y=3.20
 Ref: **11 125** Ref: **71** X=2.40 Y=4.90

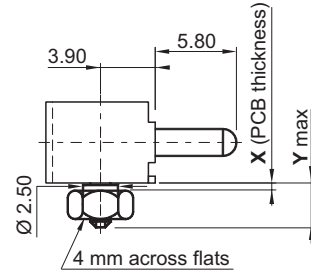

▶ LOCKING DEVICE COMPATIBILITY CHART

		R P		R P		R P		R P		R P		R P		R P		R P	
Compatible																Receptacle	Moulding
																Plug	
P																	290
R																	231
P																	211
R																	207
P																	205
R																	203
P																	201
R																	201
		Receptacle	Plug									Male locking devices					
		Moulding		232	219	215	212	210	208	204	202	Female locking devices					

► MALE LOCKING STYLES

PLUG & RECEPTACLE

JACK 1/4 TURN LOCK, FREE CONNECTOR

Ref: **201**

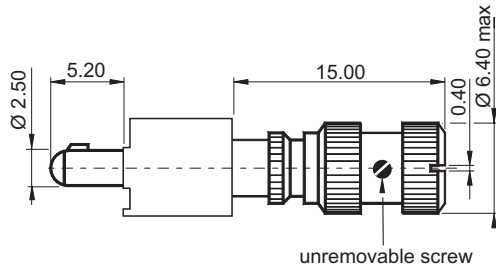

JACKSCREW, FREE CONNECTOR

Ref: **211** Ref : **51**

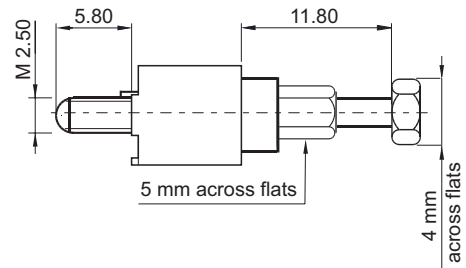

JACK 1/4 TURN LOCK, TRANSVERSE MOUNT

Ref: **203** PCB thickness 1.60

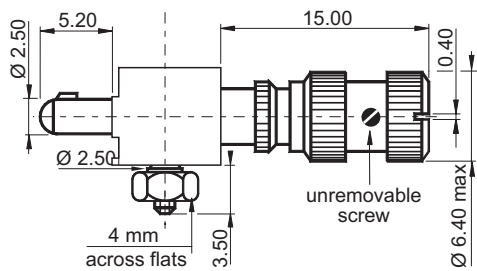

JACKSCREW, VERTICAL MOUNT

Ref: **231** Ref : **46**

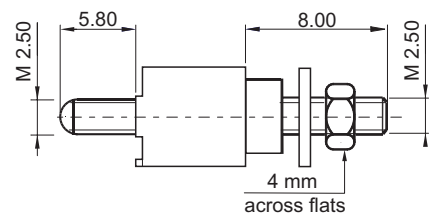

JACKSCREW, FREE CONNECTOR

Ref: **207** Ref : **47**

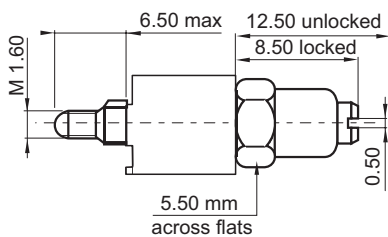

JACKSCREW, VERTICAL MOUNT

Ref: **290** Ref : **81**

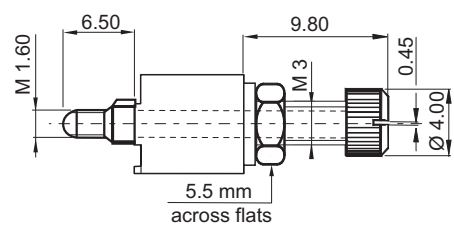

► FEMALE LOCKING STYLES

PLUG & RECEPTACLE

JACK 1/4 TURN LOCK, VERTICAL MOUNT

Ref: **202**

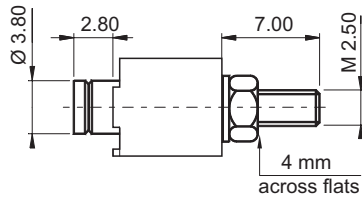

JACKSCREW, TRANSVERSE MOUNT

Ref: **212** Ref : **52**

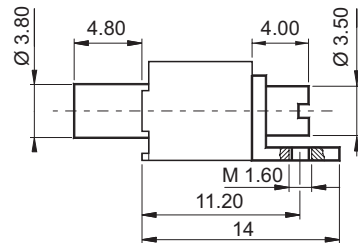

JACK 1/4 TURN LOCK, TRANSVERSE MOUNT

Ref: **204**

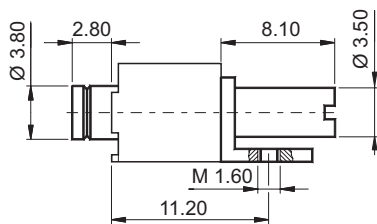

JACKSCREW, VERTICAL MOUNT

Ref: **215** Ref : **53**

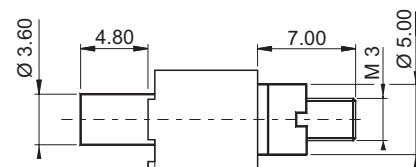

JACKSCREW, TRANSVERSE MOUNT

Ref: **10 208** Ref : **48** PCB thickness 1.60
 Ref: **11 208** Ref : **79** PCB thickness 2.40

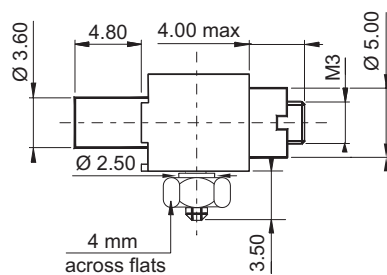

JACKSCREW, VERTICAL MOUNT

Ref: **219** Ref : **80**

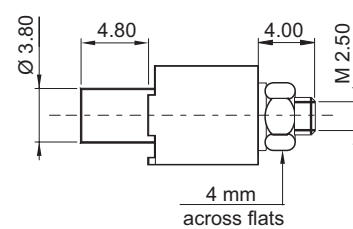

JACKSCREW, FREE CONNECTOR

Ref: **210** Ref : **50**

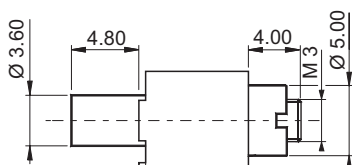

ROTATING JACKSCREW, FREE CONNECTOR

Ref: **232** Ref : **45**

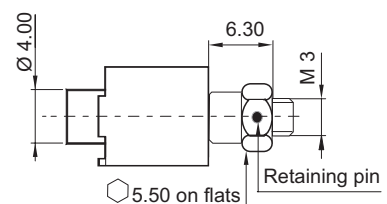

▶ MATING SIDE LAYOUT VIEW

PLUG

RECEPTACLE

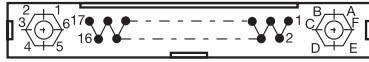

017

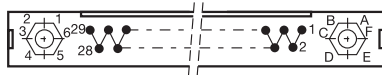
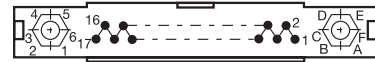

029

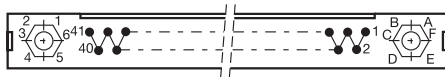
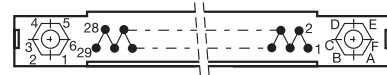

041

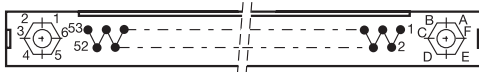
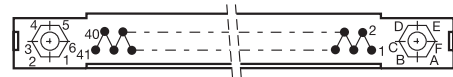

053

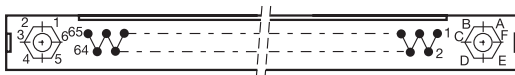
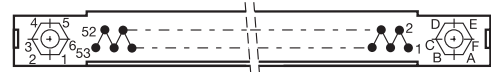

065

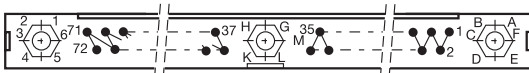
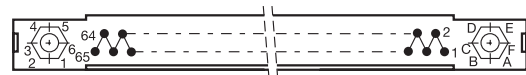

072

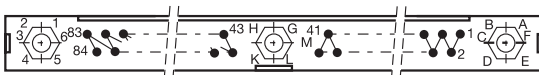
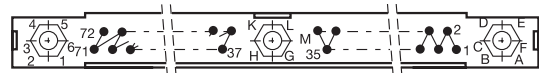

084

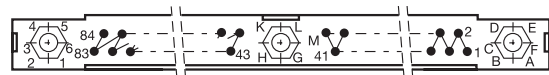

096

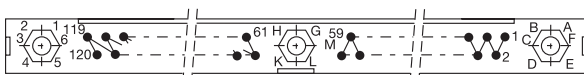
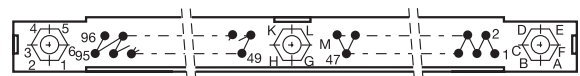

120

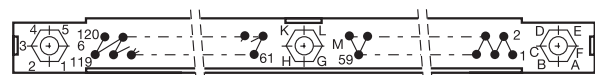

▶ PANEL PREPARATION DETAILS

17 TO 65 CONTACTS

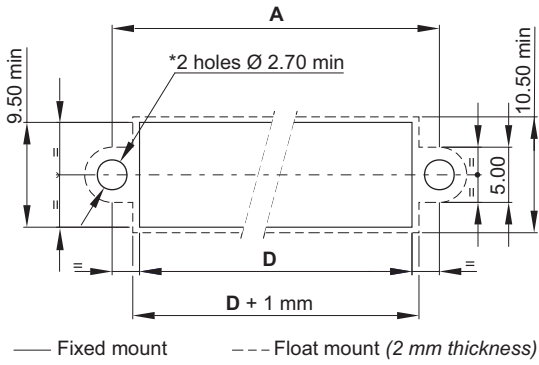

72 TO 120 CONTACTS

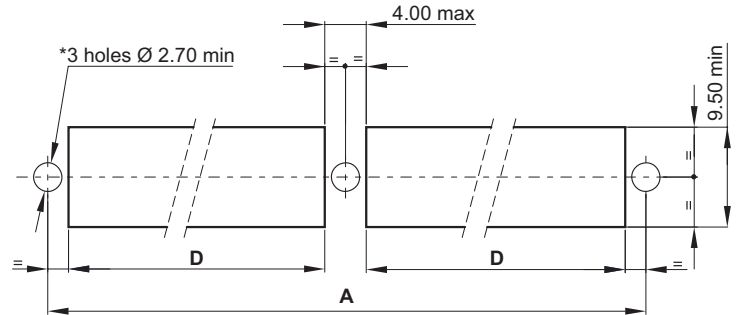

Panel: Female or male, plug or receptacle, terminations 20 - 40 - 51
Guide styles: 111 - 121 - 126 - 127 - 130 - 190 (Fixed Mount) - 113 - 123 (Float Mount)
Locking styles: 202 - 215* - 219 - 231

No. of contacts	17	29	41	53	65	72	84	96	120
A	30.48	45.72	60.96	76.20	91.44	106.68	121.92	137.16	167.64
D	25.90	41.10	56.40	71.60	86.90	48.50	56.00	63.30	78.80

* for ref: 215, holes Ø 3.20 mm

► BOARD PREPARATION DETAILS

MOTHER BOARD

17 TO 65 CONTACTS

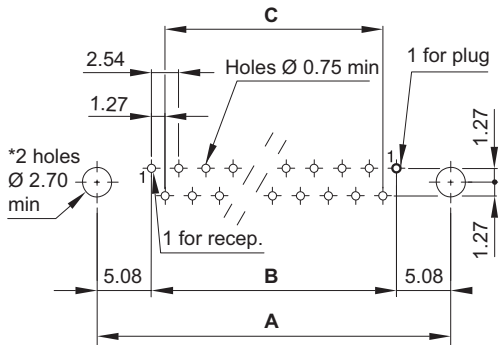

72 TO 120 CONTACTS

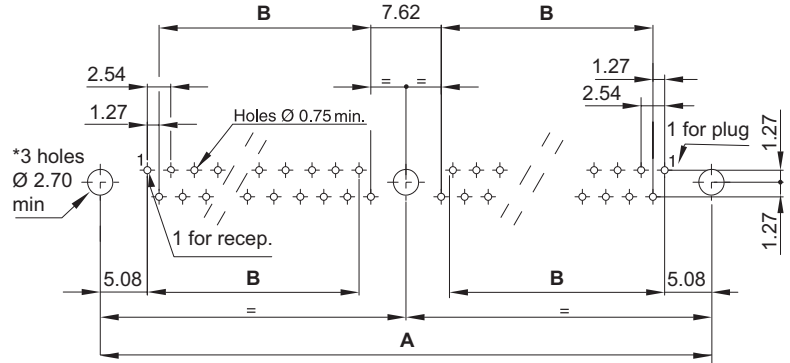

Mother Board: Female or male, plug or receptacle, straight solder termination
 Guide styles: 111 - 121 - 126 - 127 - 130 - 190 Locking styles: 202 - 215* - 219 - 231

* for ref: 215, holes Ø 3.20 mm

DAUGHTER BOARD

17 TO 65 CONTACTS

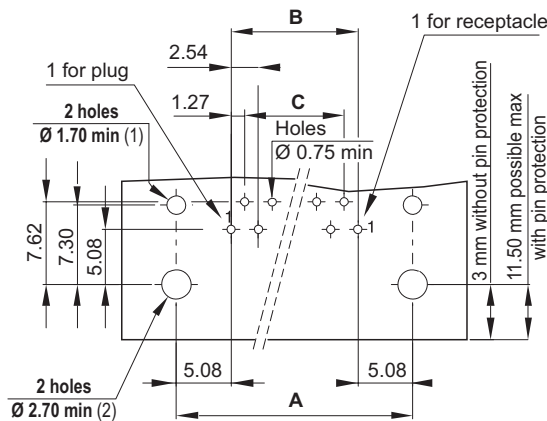

72 TO 120 CONTACTS

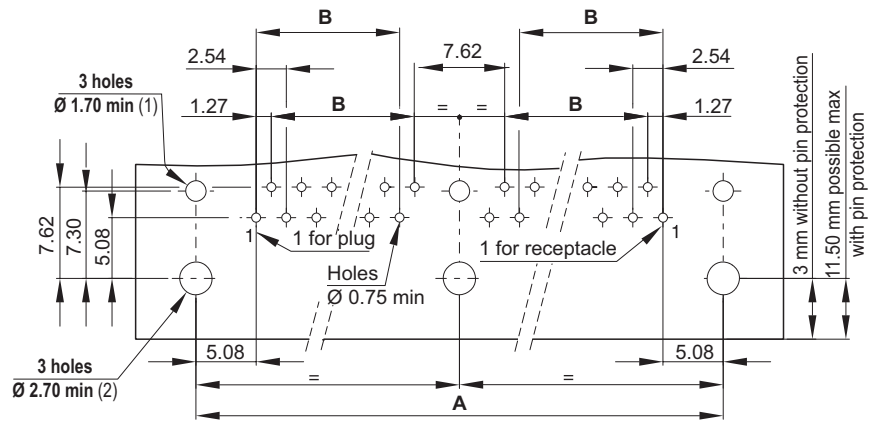

Daughter Board: Female or male, plug or receptacle, 90° termination

(1) Guide styles: 124 - 131 - 132 - 133 - 145 Locking styles: 204 - 212

(2) Guide styles: 110 - 125 - 191 Locking styles: 203 - 208

No. of contacts	17	29	41	53	65	72	84	96	120
A	30.48	45.72	60.96	76.20	91.44	106.68	121.92	137.16	167.64
B	20.32	35.56	50.80	66.04	81.28	43.18	50.80	58.42	73.66
D	17.78	33.02	48.26	63.50	78.74	-	-	-	-

TECHNICAL CHARACTERISTICS

Contact diameter	HYPERTAC® type Ø 0.60 mm rear removable
Number of contact	53
Pitch	2.54mm between rows 1.27mm between quicuncial contacts
Rows	2

MATERIALS & PLATINGS

Contact	Brass or bronze
Moulding	Glass fiber filled diallyl - Phtalate
Guides	Stainless steel or nickel plated brass

	Standard	ESA
Pin body	0.25 µm Gold / 1.27 µm Ni	1.27 µm Gold / 1.27 µm Ni (min)
Socket body	0.25 µm Gold / 1.27 µm Ni on activ area 1.27 µm Ni on non activ area	0.25 µm Gold / 1.27 µm Ni (min)
Socket wires	1 µm Gold / 0.20 µm Ni	1.27 µm Gold / 0.20 µm Ni (min)

ELECTRICAL

Current rating (at 25°C)	Standard: 3 A max ESA: 5 A max
Dielectric withstanding voltage	1200 Vrms
Contact resistance	≤ 8 mΩ
Insulation resistance	> 10 ⁴ mΩ (500 Vcc)

MECHANICAL

Mating & unmating cycle	5000
Guiding	By two outside guides (2 guiding styles) and one central guide (3 guiding styles)
Keying	By rotating of outside polarised guides (up to 36 keying)

ENVIRONMENTAL

Temperature range	-55° C + 125° C
Conformity	NF C-UTE C 93-424

Dimension are in mm

HOW TO ORDER

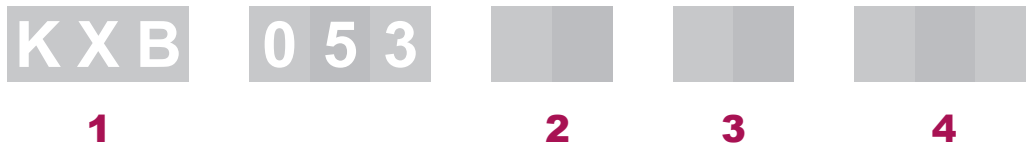

1 ▶ THERMOPLASTIC MATERIAL

X

2 ▶ MOULDING POLARITY

NF C-UTE C 93-424 MIL-C-55302 SPACE GRADE

12	14	54	Female plug	1A	1C	5A	Tinned female plug**	26	28	46	Tinned female receptacle*
13	15	55	Male plug	1B	1D	5B	Tinned male plug**	27	29	47	Tinned male receptacle*
16	18	56	Tinned female plug*	22	24	44	Female receptacle	2A	2C	-	Tinned female receptacle**
17	19	57	Tinned male plug*	23	25	45	Male receptacle	2B	2D	-	Tinned male receptacle**

3 ▶ TERMINATION STYLES

10	Through board solder - 90° - length 3 mm	21	Double crimp	51	Wire wrap (3 wrapping levels)
11	Through board solder - 90° - length 4 mm	30	Through board solder - straight	91	Female - male
20	Crimp	40	Solder bucket		

4 ▶ MOUNTING HARDWARE

GUIDE STYLES***

110	Male polarised, transverse mount, standard plug	131	Male unpolarised, transverse mount
121	Female polarised, vertical mount	145	Male polarised, transverse mount on receptacle only
124	Female polarised, transverse mount	191	Male power or mass contact, vertical mount
125	Male unpolarised, transverse mount		

LOCKING STYLES***

FEMALE RECEPTACLE		MALE PLUG	
204	1/4 turn, transverse mount	218	Jackscrew, transverse mount
		203	1/4 turn, transverse mount

* For 90° & straight terminations (splicing on PCB)
 ** RoHS compliant for 90° & straight terminations (splicing on PCB)
 *** Refer to page 3 for details for mounting hardware

► CONNECTOR DIMENSIONS

PLUG

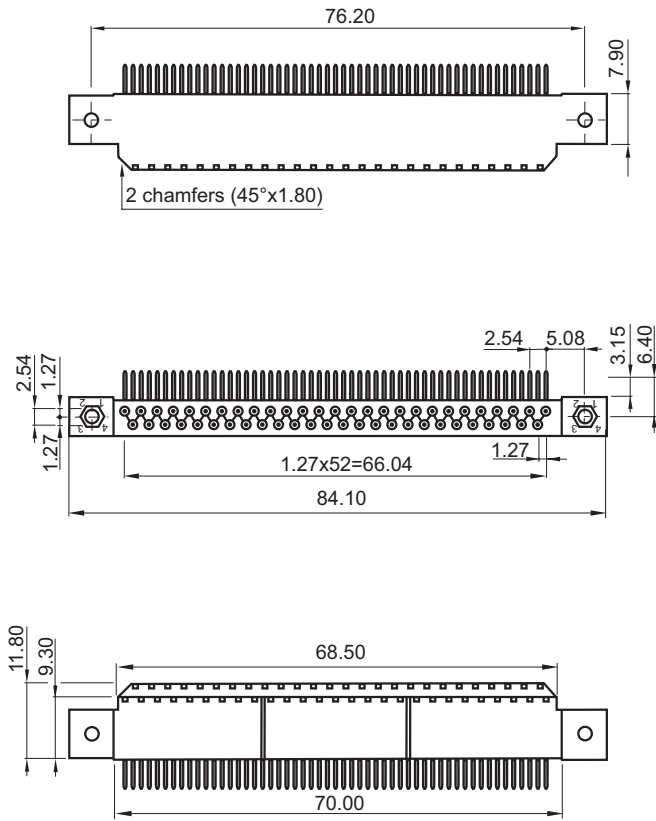

RECEPTACLE

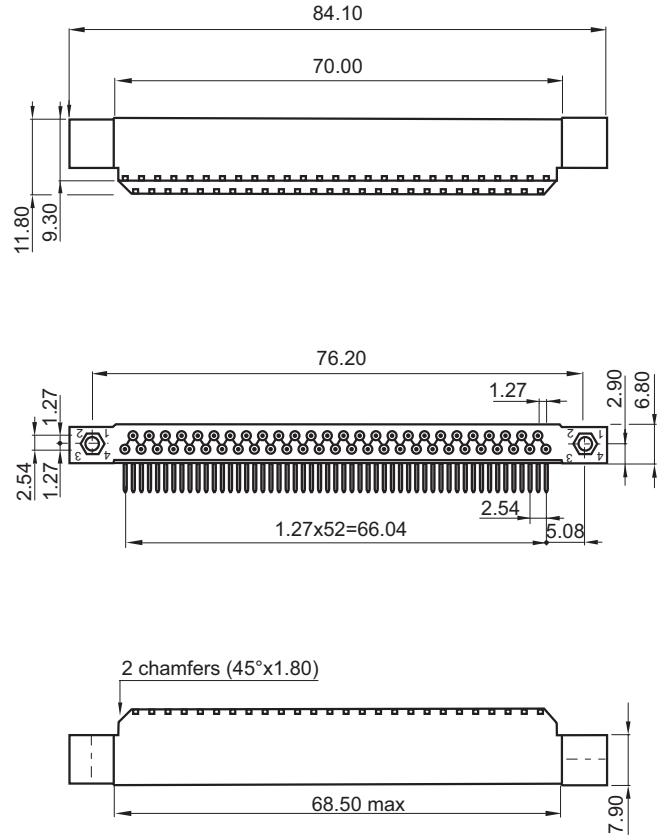

TECHNICAL CHARACTERISTICS

Contact diameter	HYPERTAC® type Ø 0.60 mm rear removable
Number of contact	Up to 160
Pitch	2.54mm between rows 1.27mm between quicuncial contacts
Rows	3

MATERIALS & PLATINGS

Contact	Brass or bronze
Moulding	Glass fiber filled diallyl - Phtalate
Guides	Stainless steel or nickel plated brass

	Standard	ESA
Pin body	0.25 µm Gold / 1.27 µm Ni	1.27 µm Gold / 1.27 µm Ni (min)
Socket body	0.25 µm Gold / 1.27 µm Ni on activ area 1.27 µm Ni on non activ area	0.25 µm Gold / 1.27 µm Ni (min)
Socket wires	1 µm Gold / 0.20 µm Ni	1.27 µm Gold / 0.20 µm Ni (min)

ELECTRICAL

Current rating (at 25°C)	Standard: 3 A max ESA: 5 A max
Dielectric withstanding voltage	1200 Vrms
Contact resistance	≤ 8 mΩ
Insulation resistance	> 104 mΩ (500 Vcc)

MECHANICAL

Mating & unmating cycle	5000
Guiding	By two outside guides (2 guiding styles) and one central guide (3 guiding styles)
Keying	By rotating of outside polarised guides (up to 36 keying)

ENVIRONMENTAL

Temperature range	-55° C + 125° C
Conformity	MIL C 55302, ESA/ESCC3401/016 - 3401/017, NF C-UTE C 93-424

Dimension are in mm

HOW TO ORDER



1 ▸ SERIES

2 ▸ PITCH OR TYPE **N** 1.27 MM PITCH, REAR REMOVABLE CONTACTS

3 ▸ MODEL **C** 3 ROWS CENTERED FIXING **D** 3 ROWS UNCENTERED FIXING

4 ▸ NUMBER OF CONTACTS

KNC	062	080	098	160					
KND	026	044	062	080	098	108	126	144	

5 ▸ MOULDING POLARITY

NF C-UTE C 93-424 **MIL-C-55302** **ESA/ESCC 3401/01601B** **SPACE GRADE**

12	14	54	54	Female plug	1A	1C	-	5A	Tinned female plug**	26	28	-	46	Tinned female receptacle*
13	15	55	55	Male plug	1B	1D	-	5B	Tinned male plug**	27	29	-	47	Tinned male receptacle*
16	18	-	56	Tinned female plug*	22	24	44	44	Female receptacle	2A	2C	-	-	Tinned female receptacle**
17	19	-	57	Tinned male plug*	23	25	45	45	Male receptacle	2B	2D	-	-	Tinned male receptacle**

6 ▸ TERMINATION STYLES

10	Through board solder - 90° - length 3 mm	21	Double crimp	51	Wire wrap (3 wrapping levels)
11	Through board solder - 90° - length 4 mm	30	Through board solder - straight	91	Female - male
20	Crimp	40	Solder bucket		

7 ▸ MOUNTING HARDWARE

GUIDE STYLES (consult us for special guides)

110	Male polarised, transverse mount, standard plug	145	Male polarised, transverse mount on receptacle only	131	Male unpolarised, transverse mount
111	Male polarised, vertical mount	190	Female power or mass contact, vertical mount	132	Female unpolarised, transverse mount
113	Male polarised, float mount	125	Male unpolarised, transverse mount	133	Female all polarised, transverse mount
121	Female polarised, vertical mount	126	Female unpolarised, vertical mount	191	Male power or mass contact, vertical mount
123	Female polarised, float mount	127	Male unpolarised, vertical mount		
124	Female polarised, transverse mount	130	Female unpolarised, vertical mount		

LOCKING STYLES

MALE PLUG		FEMALE RECEPTACLE	
201	1/4 turn, free connector	202	1/4 turn, vertical mount
203	1/4 turn, transverse mount	204	1/4 turn, transverse mount
207	Jackscrew, free connector	208	Jackscrew, transverse mount
211	Jackscrew, free connector	210	Jackscrew, free connector
290	Jackscrew, vertical mount	212	Jackscrew, transverse mount
		215	Jackscrew, vertical mount
		219	Jackscrew, vertical mount
		232	Jackscrew, with operation button

* For 90° & straight terminations (splicing on PCB)

** RoHS compliant for 90° & straight terminations (splicing on PCB)

HYPERTAC & ESA CORRESPONDANCE TABLE

HYPERTAC

KNC

34 01 016 01 B

1

2

3

4

5

6

1 ▶ ESCC COMPONENT NUMBER

2 ▶ MOUNTING

HYPERTAC

ESA

Plug KNB 017	01
Plug KNB 029	02
Plug KNB 041	03
Plug KNB 053	04
Plug KNB 065	05
Plug KNB 084	07

Plug KNB 096	08
Plug KNB 120	10
Plug KNC 160	12
Receptacle KNB 017	13
Receptacle KNB 029	14
Receptacle KNB 041	15

Receptacle KNB 053	16
Receptacle KNB 065	17
Receptacle KNB 084	19
Receptacle KNB 096	20
Receptacle KNB 120	22
Receptacle KNC 160	24

Plug KNB 072	56
Receptacle KNB 072	57
Plug KNC 062	58
Receptacle KNC 062	59
Plug KNC 080	60
Receptacle KNC 080	61

Plug KNC 098	62
Receptacle KNC 098	63

REMINDER SPATIAL P.P.P. (Party Polarity Protection)

Female receptacle	44
Male receptacle	45

Plug female	54
Plug male	55

EXAMPLE

KNB 029 **44** 40 113
P.P.P.

3 ▶ TERMINATION STYLE

HYPERTAC

ESA

Bent male 10	MC
Bent long male 11	ML
Crimp male 20	MR
Straight male 30	MD

Solder bucket male 40	MS
Mini-wrapping male 51	MY
Bent female 10	FC
Bent long female 11	FL

Crimp female 20	FR
Straight female 30	FD
Solder bucket female 40	FS
Mini-wrapping female 51	FY

Female-male 91	FM
----------------	----

4 ▶ LOCKING TYPE - ON LEFT SIDE

HYPERTAC

ESA

Guideless connector	00
KNB 10 125	26
KNC 10 125	27
KN 127	28
KN 126	29
KNB 131	31
KNB 132	32

KNB 10 110	33
KNC 10 110	34
KN 111	35
KN 121	36
KNB 145	40
KNB 124	41
KNC 10 230	43

KN 232	45
KN 231	46
KN 207	47
KNB 10 208	48
KNC 10 209	49
KN 210	50
KN 211	51

KNB 212	52
KN 215	53
KN 123	54
KN 113	55
KNB 11 125	71
KNB 11 110	72
KNB 10 230	73

KNC 124	74
KNC 132	75
KNC 11 110	76
KNC 11 125	77
KNB 11 208	79
KN 219	80
KN 290*	81

5 ▶ LOCKING TYPE - IN CENTER

00 FOR 2 GUIDE CONNECTORS

- - FOR 3 GUIDE CONNECTORS (see table 4, LOCKING TYPE - ON LEFT SIDE)

6 ▶ LOCKING TYPE - ON RIGHT SIDE

(see table 4, LOCKING TYPE - ON LEFT SIDE)

* Please consult us

▶ CONTACT TERMINATIONS

PLUG

RECEPTACLE

MALE

FEMALE

FEMALE

MALE

90° THROUGH BOARD SOLDER

Ref: **10** (X=3) Ref : **MC & FC** - Ref: **11** (X=4) Ref : **ML & FL**

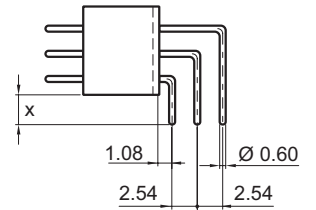
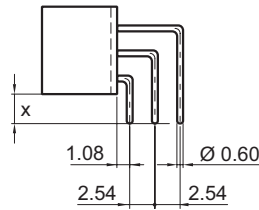
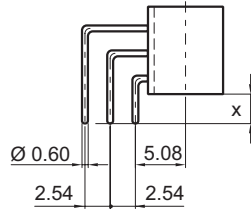
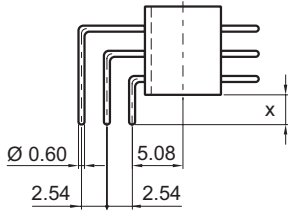

CRIMP (AWG 28-22)

Ref: **20** Ref : **MR & FR**

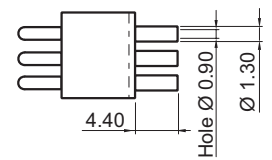
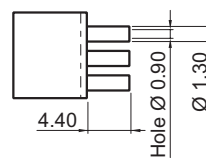
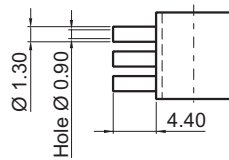
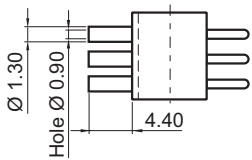

CRIMP (AWG 28-22)

Ref: **21**

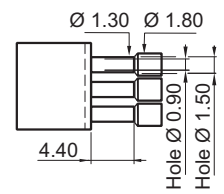
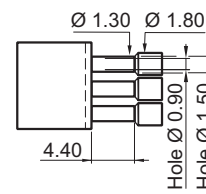
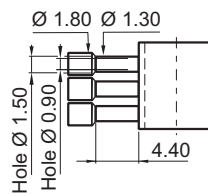
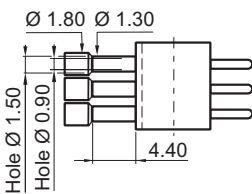

STRAIGHT THROUGH BOARD SOLDER

Ref: **30** Ref : **MD & FD**

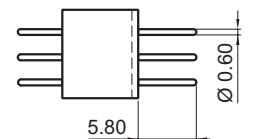
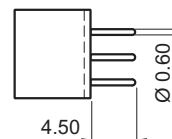
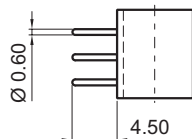
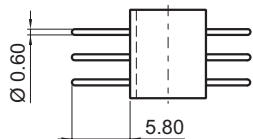

▶ CONTACT TERMINATIONS

PLUG

RECEPTACLE

MALE

FEMALE

FEMALE

MALE

SOLDER BUCKET (AWG 22 max)

Ref: 40 Ref: MS & FS

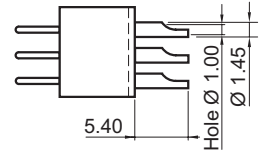
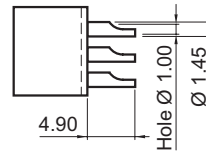
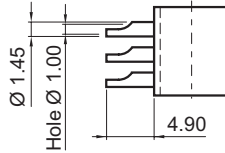
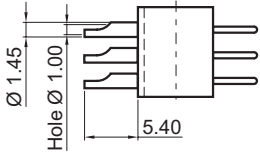

WIRE WRAP (3 wrapping levels)

Ref: 51 Ref: MY & FY

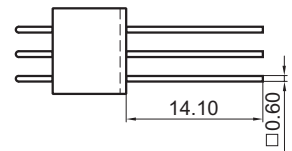
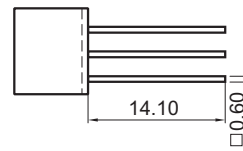
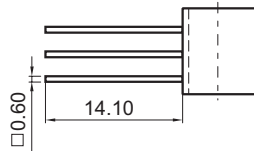
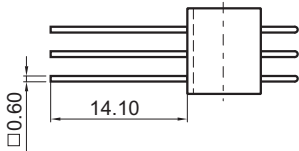

SAVER (male-male)

Ref: 90

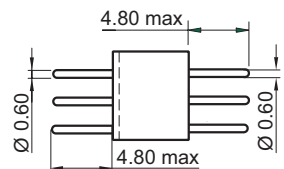
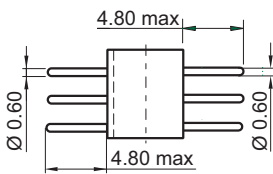

SAVER (female-male)

Ref: 91 Ref: FM

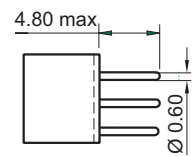
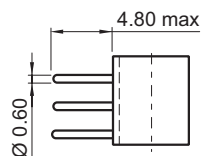

► DIMENSIONS

PLUG

RECEPTACLE

26 TO 98 CONTACTS

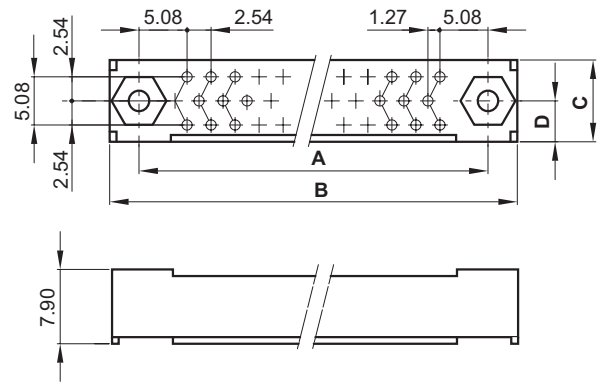
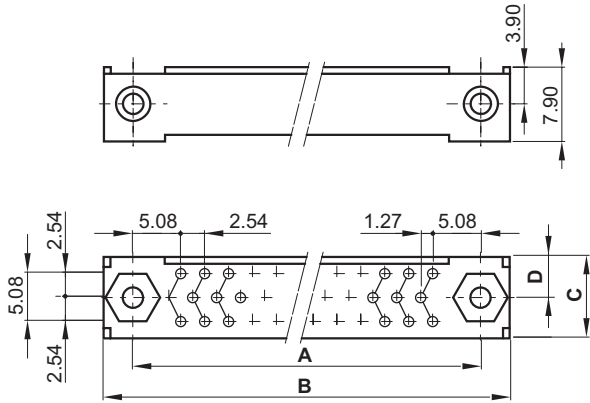

108 TO 160 CONTACTS

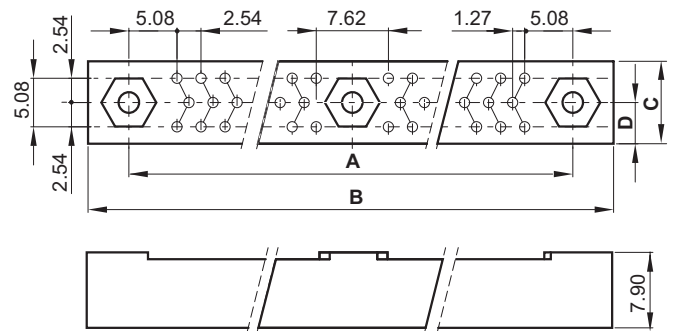
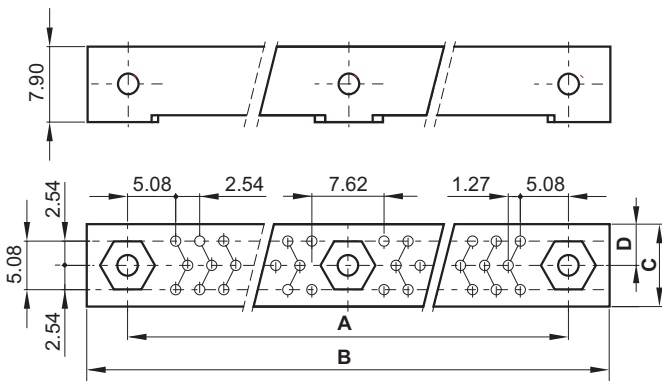

		No. of contacts	26	44	62	80	98	108	126	144	160
KNC	Plug & Receptacle	A	-	-	60.96	76.20	91.44	-	-	-	149.86
		B max	-	-	69.00	84.20	99.50	-	-	-	158.00
	Plug	C max	-	-	9.45	9.45	9.45	-	-	-	9.30
		D	-	-	4.42	4.42	4.42	-	-	-	4.70
	Receptacle	C max	-	-	9.30	9.30	9.30	-	-	-	9.30
		D	-	-	4.70	4.70	4.70	-	-	-	4.70
KND	Plug & Receptacle	A	30.48	45.72	60.96	76.20	91.44	106.68	121.92	137.16	-
		B max	38.50	53.70	69.00	84.20	99.50	114.70	129.90	145.20	-
	Plug	C min	8.95	8.95	8.95	8.95	8.95	8.95	8.95	8.95	-
		C max	9.55	9.55	9.55	9.55	9.55	9.55	9.55	9.55	-
		D	3.15	3.15	3.15	3.15	3.15	3.15	3.15	3.15	-
	Receptacle	C max	9.35	9.35	9.35	9.35	9.35	9.35	9.35	9.35	-
		D	3.10	3.10	3.10	3.10	3.10	3.10	3.10	3.10	-

MR 23	FR 22	FP 12	MP 13	MR 23	FR 22	FP 12	MP 13	MR 23	FR 22	FP 12	MP 13	MR 23	FR 22	FP 12	MP 13	Polarity		
																Receptacle		Moulding
															Plug			
															90°	10	11	Contact
														Straight	30	31		
														Solder bucket		40		
														Crimp	20	21		
														Wire wrap		51		

MR 23	FR 22	FP 12	MP 13	MR 23	FR 22	FP 12	MP 13	MR 23	FR 22	FP 12	MP 13	MR 23	FR 22	FP 12	MP 13			
																	191	Guiding devices
																145		
																131		
																127		
																125		
																113		
																111		
																110		

126	124	123	121
Guiding devices			

Male guides

Female guides

► GUIDE STYLES

PLUG & RECEPTACLE

MALE

POLARISED VERTICAL MOUNT

Ref: 111 Ref ©: 35

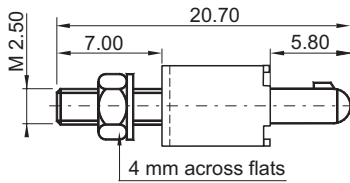

FEMALE

POLARISED VERTICAL FLOAT MOUNT

Ref: 123 Ref ©: 54

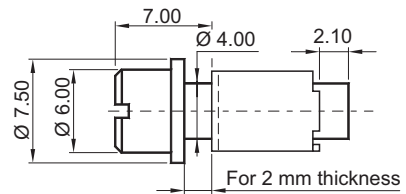

POLARISED VERTICAL FLOAT MOUNT

Ref: 113 Ref ©: 55

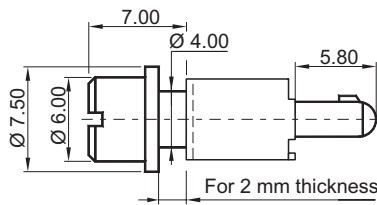

POLARISED TRANSVERSE MOUNT

Ref: 124 Ref ©: 74

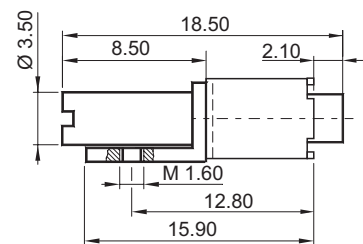

UNPOLARISED VERTICAL MOUNT

Ref: 127 Ref ©: 28

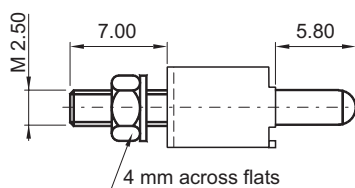

UNPOLARISED VERTICAL MOUNT

Ref: 126 Ref ©: 29

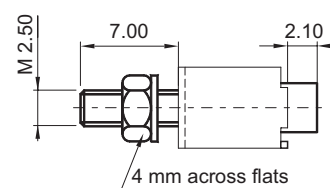

UNPOLARISED TRANSVERSE MOUNT

Ref: 131

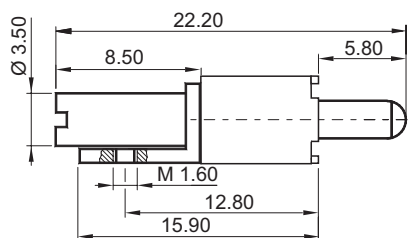

ALL POLARISED VERTICAL MOUNT

Ref: 130

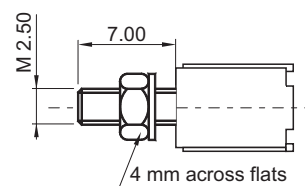

► GUIDE STYLES

PLUG & RECEPTACLE

MALE

POLARISED TRANSVERSE MOUNT

Ref: 145

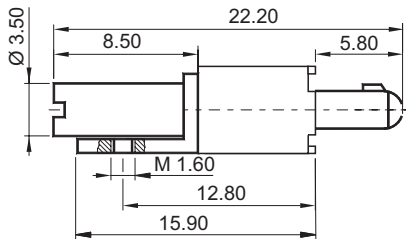

FEMALE

UNPOLARISED TRANSVERSE MOUNT

Ref: 132 Ref: 75

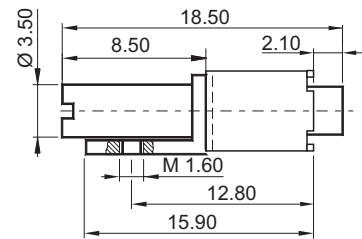

POLARISED VERTICAL MOUNT

Ref: 121 Ref: 36

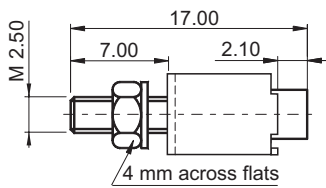

ALL POLARISED TRANSVERSE MOUNT

Ref: 133

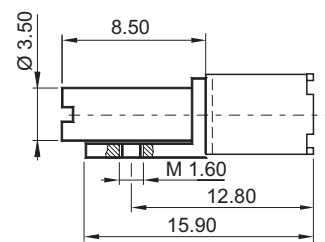

▶ GUIDE STYLES

PLUG & RECEPTACLE

MALE

FEMALE

POWER OR MASS VERTICAL MOUNT

POWER OR MASS VERTICAL MOUNT

Ref: **191** PCB thickness 1.60

Ref: **190**

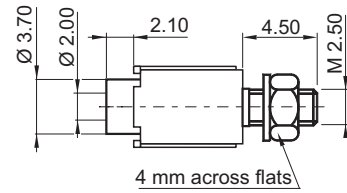
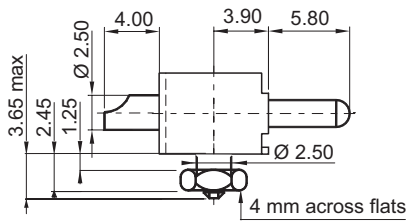

MALE PLUG ONLY

POLARISED TRANSVERSE MOUNT

UNPOLARISED TRANSVERSE MOUNT

Ref: **10 110** Ref: **34** PCB thickness 1.60

Ref: **10 125** Ref: **27** PCB thickness 1.60

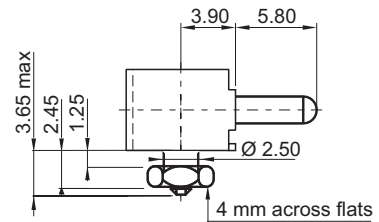
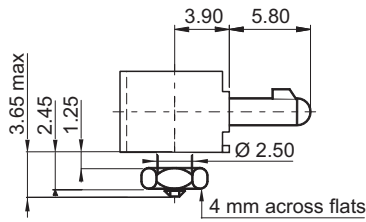

▶ LOCKING DEVICES COMPATIBILITY CHART

		R P		R P		R P		R P		R P		R P		R P		R P	
Compatible	Receptacle																
	Plug																
P	R																
P	R																
P	R																
P	R																
P	R																
P	R																
P	R																
P	R																
		Male locking devices															
		Female locking devices															
Receptacle	Plug																
Moulding		232	219	215	212	210	208	204	202								

► MALE LOCKING STYLES

PLUG & RECEPTACLE

JACK 1/4 TURN LOCK, FREE CONNECTOR

Ref: **201**

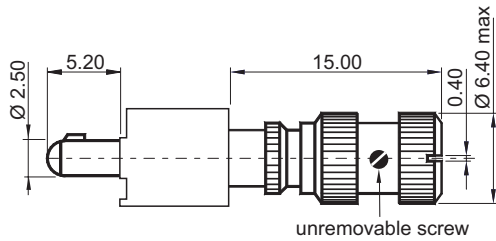

JACKSCREW, FREE CONNECTOR

Ref: **211** Ref : **51**

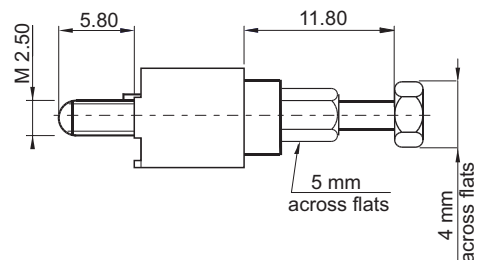

JACK 1/4 TURN LOCK, TRANSVERSE MOUNT

Ref: **206**

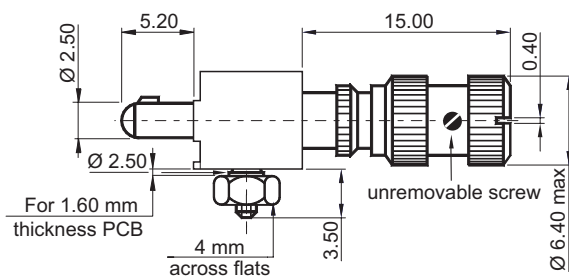

JACKSCREW, VERTICAL MOUNT

Ref: **231** Ref : **46**

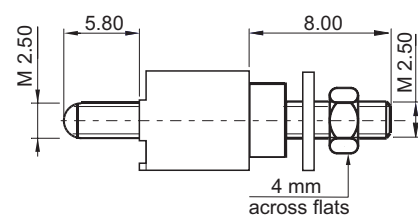

JACKSCREW, FREE CONNECTOR

Ref: **207** Ref : **47**

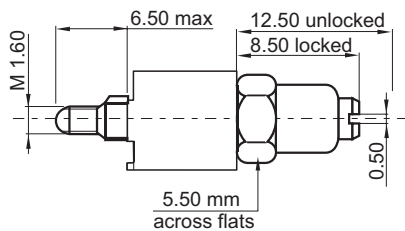

JACKSCREW, VERTICAL MOUNT

Ref: **290** Ref : **81**

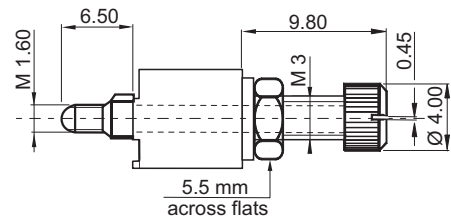

► FEMALE LOCKING STYLES

PLUG & RECEPTACLE

JACK 1/4 TURN LOCK, VERTICAL MOUNT

Ref: **202**

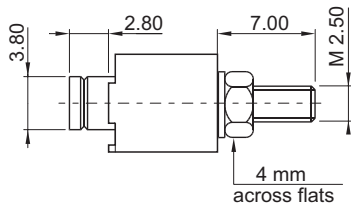

JACKSCREW, TRANSVERSE MOUNT

Ref: **212**

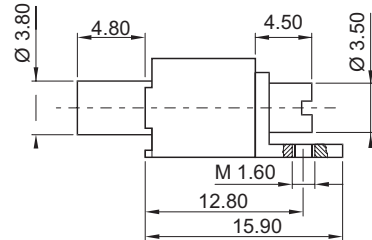

JACKSCREW, TRANSVERSE MOUNT

Ref: **10 209** Ref : **49** PCB thickness 1.60

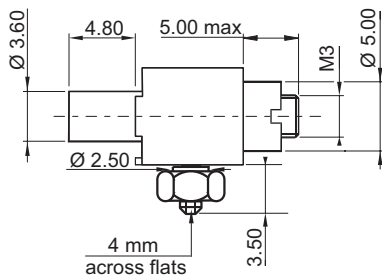

JACKSCREW, VERTICAL MOUNT

Ref: **215** Ref : **53**

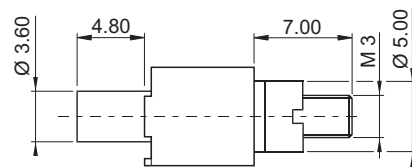

JACKSCREW, FREE CONNECTOR

Ref: **210** Ref : **50**

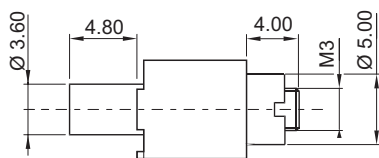

JACKSCREW, VERTICAL MOUNT

Ref: **219** Ref : **80**

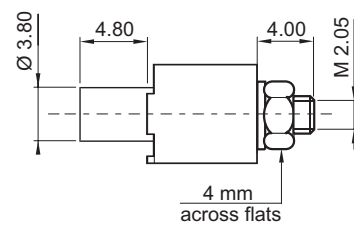

ROTATING JACKSCREW

Ref: **232**

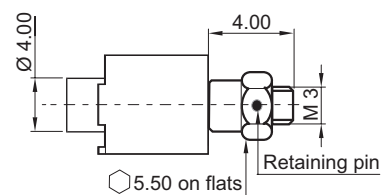

► RECEPTACLE MATING SIDE LAYOUT VIEW

26 TO 98 CONTACTS

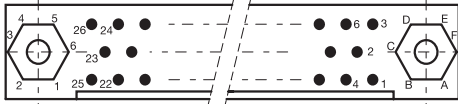

108 TO 160 CONTACTS

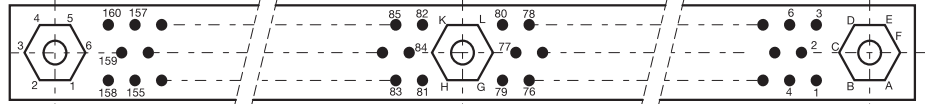

► PANEL PREPARATION DETAILS

26 TO 98 CONTACTS

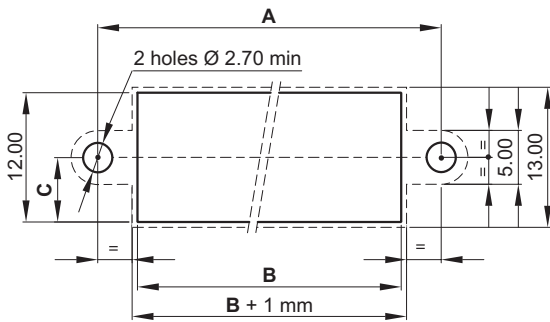

108 TO 160 CONTACTS

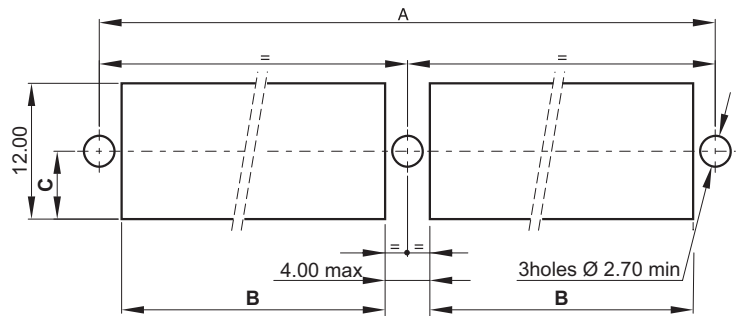

— Fixed mount --- Float mount (2 mm thickness)

Panel: Female or male, plug or receptacle

Terminations: 40 - 51

Guide styles: 111 - 121 (Fixed Mount)

Guide styles: 113 - 123 - 202 (Float Mount)

No. of contacts	26	44	62	80	98	108	126	144	160
A	30.48	45.72	60.96	76.20	91.44	106.68	121.92	137.16	149.86
B min	25.90	41.10	56.40	71.60	86.90	48.50	56.00	63.60	69.95
C (KNC)	—	—	6.00	6.00	6.00	—	—	—	6.00
C (KND)	4.73	4.73	4.73	4.73	4.73	4.73	4.73	4.73	—

► BOARD PREPARATION DETAILS

MOTHER BOARD

26 TO 98 CONTACTS

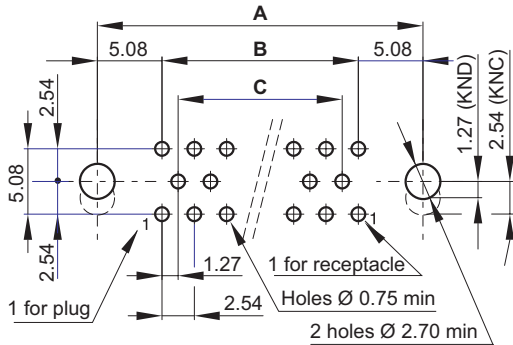

108 TO 160 CONTACTS

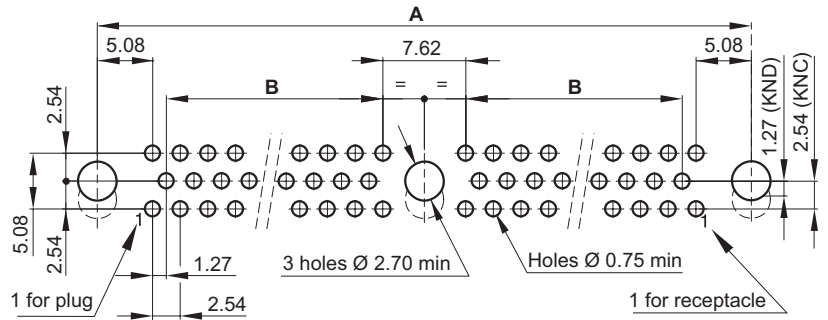

Mother Board: Female or male, plug or receptacle, straight solder termination
Guide styles: 111 - 121- 202

DAUGHTER BOARD

26 TO 98 CONTACTS

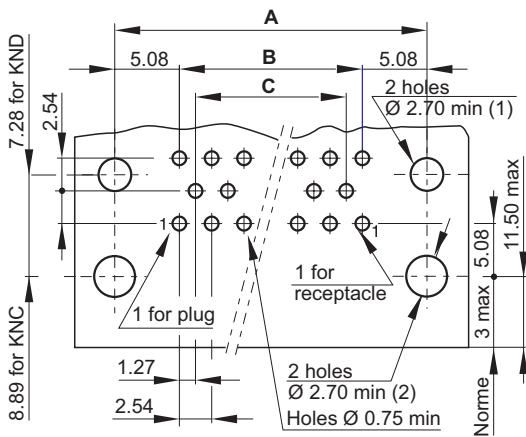

108 TO 160 CONTACTS

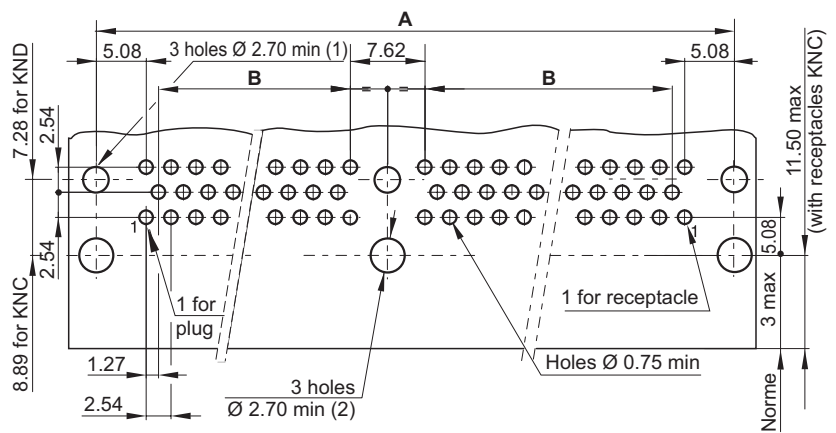

Daughter Board: Female or male, plug or receptacle, 90° termination
(1) Guide styles: 124 (2) Guide styles: 110 - 206

No. of contacts	26	44	62	80	98	108	126	144	160
A	30.48	45.72	60.96	76.20	91.44	106.68	121.92	137.16	149.86
B	20.32	35.56	50.80	66.04	81.28	43.18	50.80	58.42	64.77
C	17.78	33.02	48.26	63.50	78.74	-	-	-	-

CONTACTS

MALE

FEMALE

CRIMP TERMINATIONS AWG 22-28 (0.079 - 0.34 mm²)

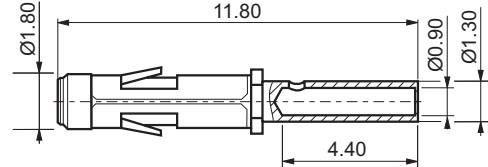
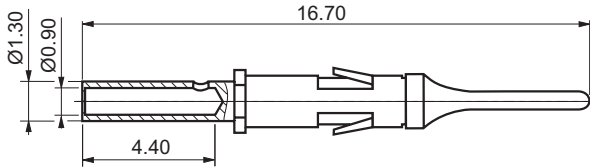

Reference	Part number
KN- ---13 20 ---	006 042 1- 20R OG
KN- ---55 20 ---	006 042 1- 20P OF
 MR	3401 017 004B

Reference	Part number
KN- ---22 20 ---	006 042 2- 20R G0
KN- ---44 20 ---	006 042 2- 20P J9
 FR	3401 017 015B

CRIMP TERMINATIONS AWG 22-28 (0.079 - 0.34 mm²) & SHEATH Ø1.45

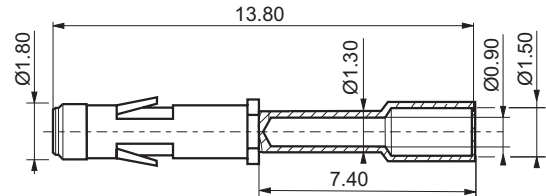
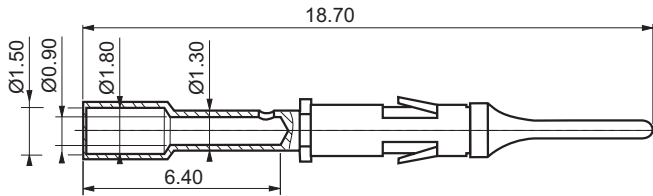

Reference	Part number
KN- ---13 20 ---	006 063 1- 21R OG
KN- ---55 20 ---	006 063 1- 20R OF

Reference	Part number
KN- ---22 20 ---	006 063 2- 21R G0
KN- ---44 20 ---	006 063 2- 21R J3

► TOOLS

CRIMP TOOL & POSITIONER



Ref: S_102
(M22520/2.01)



Contact part number	Crimp tool	AWG	Wire cross section	Positioner	Tool turret	Selector position	
006 042 1- 20R OG 006 042 2- 20R GO	ASTRO TOOL M22520/2.01	28	0.079	SS-0060000001		3	
		26	0.14			4	
		24	0.20			4	
		22	0.34			5	
	DANIELS M22520/2.01	28	0.079	SS-0060000001		3	
		26	0.14			4	
		24	0.20			4	
		22	0.34			5	
006 063 1- 21R OG 006 063 2- 21R GO	2 operations	ASTRO TOOL M22520/2.01	28	0.079	SS-0060000001		3
			26	0.14			4
			24	0.20			4
			22	0.34			5
	1 st crimp (lead)	DANIELS M22520/2.01	28	0.079	SS-0060000001		3
			26	0.14			4
			24	0.20			4
			22	0.34			5
	2 nd crimp (sheath)	ASTRO TOOL M22520/2.01	28	0.079	SS-0060000002		*
			26	0.14			6
			24	0.20			7
			22	0.34			7
		DANIELS M22520/2.01	28	0.079	SS-0060000002		*
			26	0.14			6
			24	0.20			7
			22	0.34			7
1 operation	52007	28	0.079		SP717	2	
		26	0.14			3	
		24	0.20			4	
		22	0.34			4	

INSERTION



SM-0060000001

EXTRACTION



SD-0060000006

ALIGNMENT COMBS

for 90° through board termination

2 fixing points **SP. 006 00 00 006**
3 fixing points **SP. 006 00 00 004**

SCREWDRIVER FOR M3 NUT

208 locking devices **S_075**
215 locking devices

▶ ACCESSORIES

ANTISTATIC PIN PROTECTOR

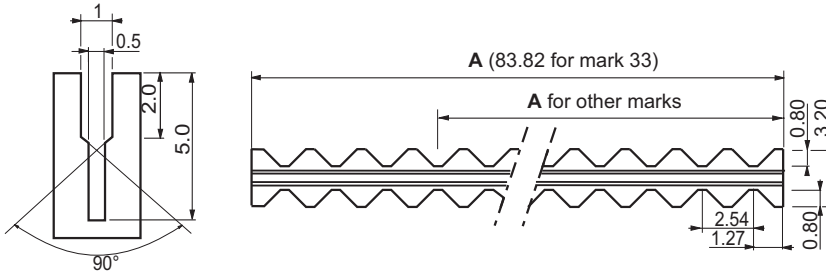

Ordering information

KNB - - - - 314

↑
Ref

Use	A	Ref	Use	A	Ref
KNB 017	24.13	009	KNB 096	62.23	024
KND 026			KND 144		
KNB 029	39.37	015	KNB 053	69.85	027
KND 044			KNC 080 & 160		
			KND 080		
KNB 072	46.99	018	KNB 120	77.47	030
KND 108					
KNB 041 & 084	54.61	021	KNB 065	83.82	033
KNC 062			KNC 098		
KND 062 & 126			KND 098		

Each part number contains only one header. To equip fully the connector, you have to order 2, 3, 4 or 6 identical headers. Header can fit on contacts or be positioned between rows.

▶ ACCESSORIES

PIN PROTECTOR (extruded polypropylene)

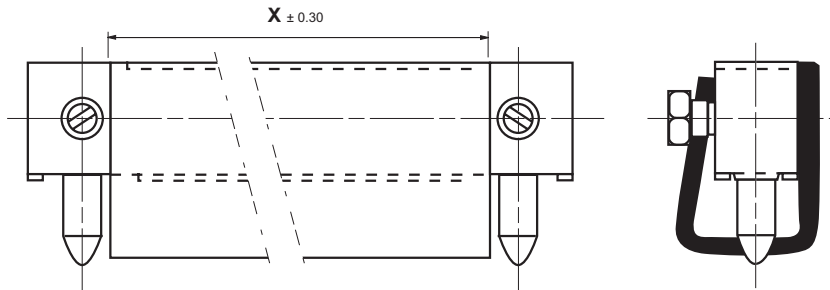

Ordering information

KN - - - - 308

B, C
or D

Number of
positions

KNB	017	029	041	053	065	072	084	096	120
X ± 0.30	25.50	40.70	56	71.20	86.50	48.40	56	63.60	78.80
Qty	1	1	1	1	1	2	2	2	2
KNC	062	080	098	119	160				
X ± 0.30	66	81.20	96.40	114.20	155.00				
Qty	1	1	1	1	1				
KND	026	044	108	126	144				
X ± 0.30	35.50	50.70	111.70	127.00	142.20				
Qty	1	1	1	1	1				

TECHNICAL CHARACTERISTICS

Contact diameter	HYPERTAC® type Ø 0.50 mm rear removable
Number of contact	Up to 162
Pitch	1.905mm between rows 1.27mm between quicuncial contacts
Rows	3

MATERIALS & PLATINGS

Contact	Brass or bronze
Moulding	Glass fiber filled diallyl - Phtalate
Guides	Stainless steel or nickel plated brass

	Standard	ESA
Pin body	0.25 µm Gold / 1.27 µm Ni	1.27 µm Gold / 1.27 µm Ni (min)
Socket body	0.25 µm Gold / 1.27 µm Ni on activ area 1.27 µm Ni on non activ area	0.25 µm Gold / 1.27 µm Ni (min)
Socket wires	1 µm Gold / 0.20 µm Ni	1.27 µm Gold / 0.20 µm Ni (min)

ELECTRICAL

Current rating (at 25°C)	3 A max
Dielectric withstanding voltage	800 Vrms
Contact resistance	≤ 8 mΩ
Insulation resistance	> 10 ⁴ mΩ (500 Vcc)

MECHANICAL

Mating & unmating cycle	5000
Guiding	By two outside guides (2 guiding styles) and one central guide (3 guiding styles)
Keying	By rotating of outside polarised guides (up to 16 keying)

ENVIRONMENTAL

Temperature range	-55° C + 125° C
Conformity	ESA/ESCC 3401/039, NF C-UTE C 93-424

Dimension are in mm

HOW TO ORDER

HYPERTAC & ESA CORRESPONDANCE TABLE



1 ▸ SERIES

2 ▸ NUMBER OF CONTACTS

0 2 6 0 4 4 0 6 2 0 8 0 0 9 8 1 4 4 1 6 2

3 ▸ MOULDING POLARITY

NF C-UTE C 93-424 ESA/ESCC 3401/03901B SPACE GRADE

12	-	54	Female plug	1A	-	-	Tinned female plug**	26	-	46	Tinned female receptacle*
13	55	55	Male plug	1B	-	-	Tinned male plug**	27	-	47	Tinned male receptacle*
16	-	56	Tinned female plug*	22	44	44	Female receptacle	2A	-	-	Tinned female receptacle**
17	-	57	Tinned male plug*	23	-	45	Male receptacle	2B	-	-	Tinned male receptacle**

4 ▸ TERMINATION STYLES

1 0	90° length 3 mm ("A" moulding)	3 0	Through board solder - straight - length 4.5 mm	5 1	Wire wrap (3 wrapping levels)
1 0	90° length 3 mm ("B" moulding)	3 1	Through board solder - straight - length 5.6 mm	9 0	Male - male
1 1	90° length 4 mm ("A" moulding)	4 0	Solder bucket	9 1	Female - male
1 3	90° length 5.5 mm ("B" moulding)	5 0	Wire wrap (2 wrapping levels)		

5 ▸ MOUNTING HARDWARE

GUIDE STYLES (consult us for special guides)

1 10	Male polarised, transverse mount ⁽¹⁾	1 27	Male unpolarised, vertical mount ⁽²⁾	1 56	Male unpolarised, transverse mount ⁽²⁾
1 11	Male polarised, vertical mount ⁽²⁾	1 28	Male unpolarised, float mount ⁽²⁾	1 73	Female unpolarised, transverse mount ⁽¹⁾
1 12	Male polarised, vertical mount ⁽²⁾	1 30	Female unpolarised, vertical mount ⁽²⁾	1 74	Female polarised, transverse mount ⁽¹⁾
1 13	Male polarised, float mount ⁽²⁾	1 33	Female unpolarised, transverse mount ⁽²⁾	1 90	Female power or mass contact, vertical mount ⁽²⁾
1 21	Female polarised, vertical mount ⁽²⁾	1 43	Female polarised, vertical mount ⁽²⁾	1 91	Male power or mass contact, transverse mount ⁽¹⁾
1 23	Female polarised, float mount ⁽²⁾	1 53	Female unpolarised, transverse mount ⁽²⁾	7 03	Female - male unpolarised guide ⁽²⁾
1 24	Female polarised, transverse mount ⁽²⁾	1 54	Female polarised, transverse mount ⁽²⁾		
1 25	Male unpolarised, transverse mount ⁽¹⁾	1 55	Male unpolarised, transverse mount ⁽²⁾		

LOCKING STYLES

FEMALE	MALE		
202	Jackscrew, vertical mount ⁽²⁾	201	Jackscrew, free connector ⁽²⁾
203	Jackscrew, transverse mount ⁽¹⁾	205	Jackscrew, transverse mount ⁽¹⁾
204	Jackscrew, transverse mount ⁽²⁾	206	Jackscrew, free connector ⁽²⁾
207	Jackscrew, vertical mount ⁽²⁾		

⁽¹⁾ Moulding A - ⁽²⁾ Moulding B

* For 90° & straight terminations (splicing on PCB)

** RoHS conform for 90° & straight terminations (splicing on PCB)

► **MOULDING STYLES**

PLUG

RECEPTACLE

ONE PART (moulding A)

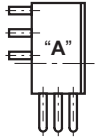

Fitted with male contacts
 ▶ 90° through board solder

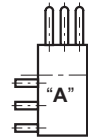

Fitted with male contacts
 ▶ 90° through board solder
 (same design as the "A" plug type but printed as receptacle)

TWO PARTS (moulding B)

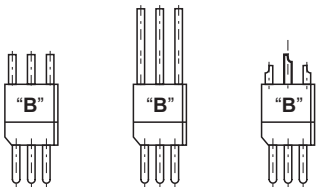

Fitted with male contacts (pins)
 ▶ Straight through board solder
 ▶ Wire wrap type
 (2 and 3 wrapping levels)
 ▶ Solder bucket

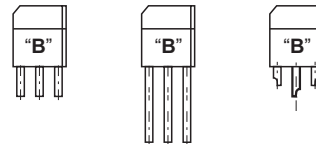

Fitted with female contacts
 ▶ Straight through board solder
 ▶ Wire wrap type
 (2 and 3 wrapping levels)
 ▶ Solder bucket
 (same design as the "B" plug type but printed as receptacle)

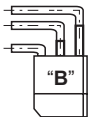

Fitted with female contacts (sockets)
 ▶ 90° through board solder
Note: the spacing of the rows for board preparation is different to the spacing of the plug fitted with the 90° termination
 ▶ Straight through board solder
 ▶ Wire wrap type
 (2 and 3 wrapping levels)
 ▶ Solder bucket

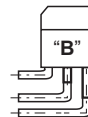

Fitted with female contacts (sockets)
 ▶ 90° through board solder
Note: the spacing of the rows for board preparation is different to the spacing of the plug fitted with the 90° termination

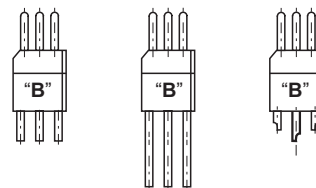
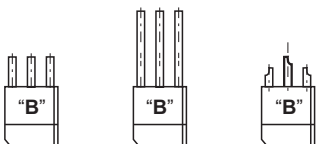

Fitted with male contacts (pins)
 ▶ Straight through board solder
 ▶ Wire wrap type
 (2 and 3 wrapping levels)
 ▶ Solder bucket
 (same design as the "B" plug type but printed as receptacle)

▶ CONTACT TERMINATIONS

PLUG

RECEPTACLE

MALE

FEMALE

FEMALE

MALE

90° THROUGH BOARD SOLDER

Ref: 10 Ref: 10 (only A Moulding)

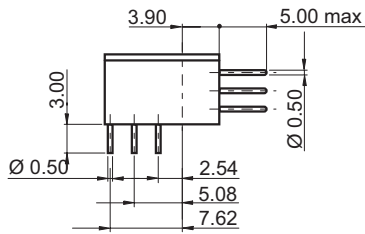

Moulding "A"

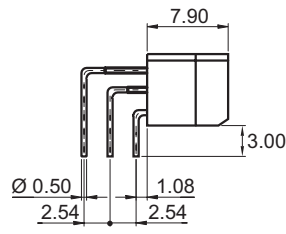

Moulding "B"

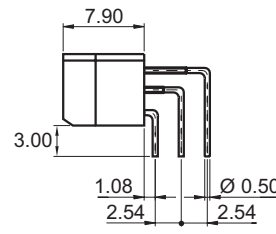

Moulding "B"

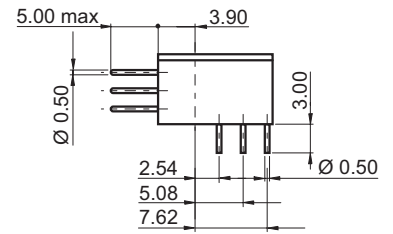

Moulding "A"

90° THROUGH BOARD SOLDER

Moulding A Ref: 11 (X=4.00) Moulding B Ref: 13 (X=5.50)

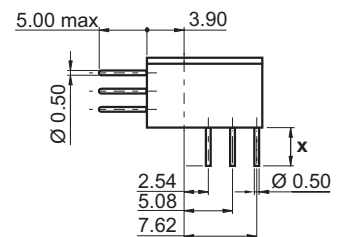
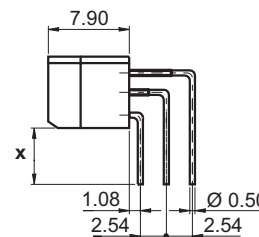
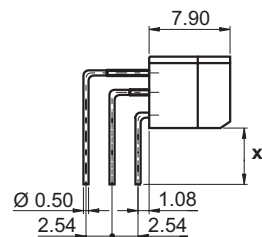
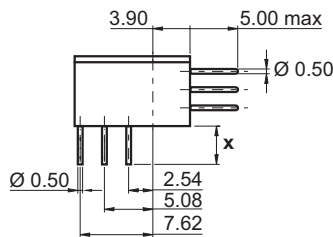

STRAIGHT THROUGH BOARD SOLDER

Ref: 30 (X=4.50) Ref: 30 Ref: 31 (X=5.60) Ref: 31

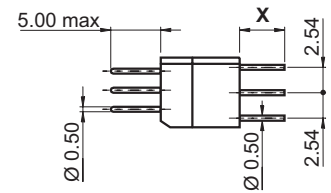
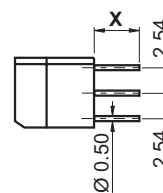
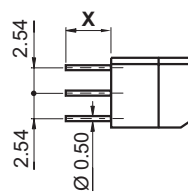
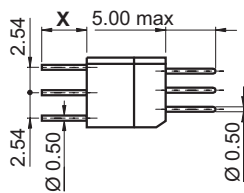

SOLDER BUCKET (AWG 26 max)

Ref: 40 Ref: 40

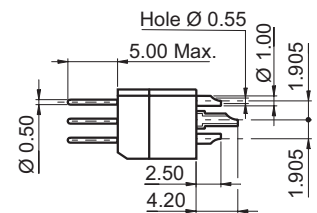
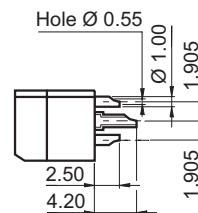
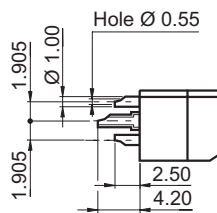
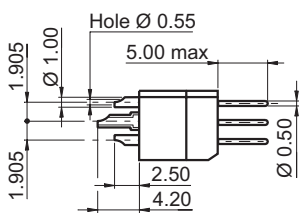

Note: moulding A and B need different preparation board details for 90° tail termination.

CONTACT TERMINATIONS

PLUG

RECEPTACLE

MALE

FEMALE

FEMALE

MALE

WIRE WRAP (2 wrapping levels)

Ref: 50 Ref: 50

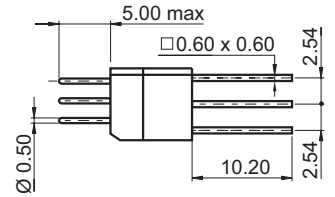
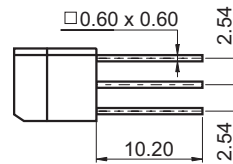
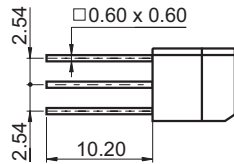
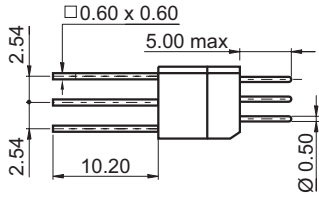

WIRE WRAP (3 wrapping levels)

Ref: 51 Ref: 51

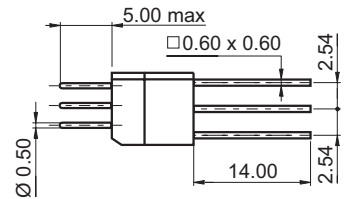
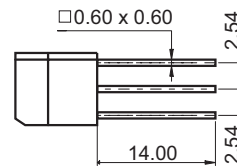
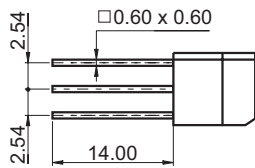
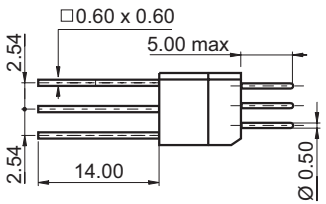

SAVER (Male-Male)

Ref: 90

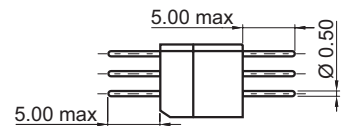
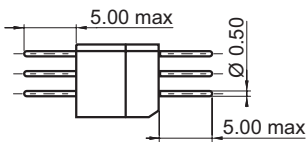

SAVER (Female-Male)

Ref: 91 Ref: 91

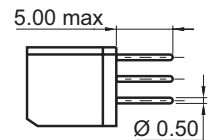
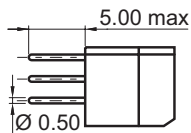

Note: moulding A and B need different preparation board details for 90° tail termination.

► DIMENSIONS

26 TO 98 CONTACTS

144 TO 162 CONTACTS

ONE PART (moulding A)

90° male plug KMC ... 13 10 ...
 90° male receptacle KMC ... 23 10 ...

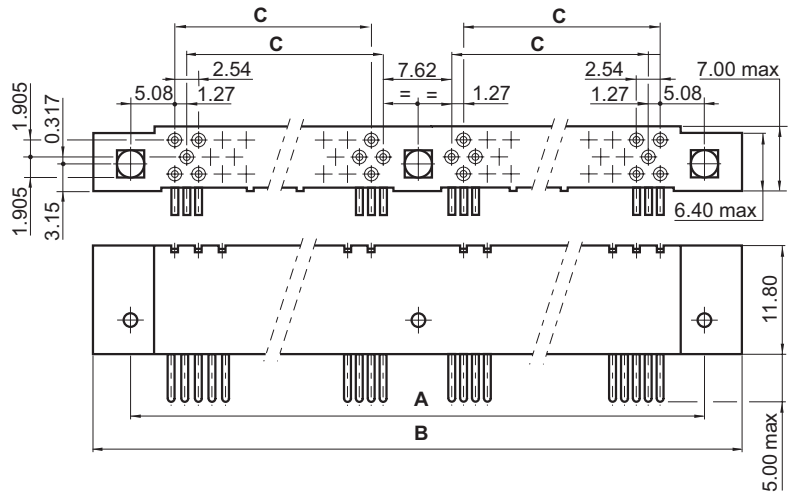
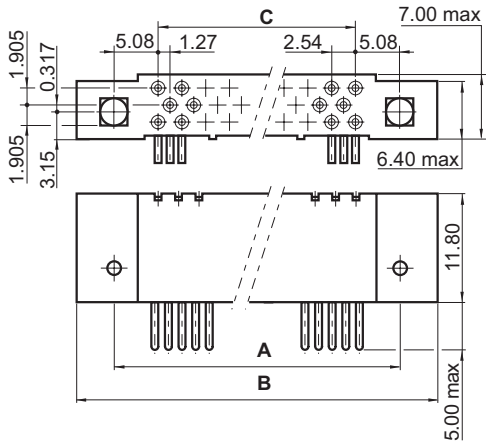

TWO PARTS (moulding B)

Female or male receptacle KMC ... 2. ...
 Female or male plug KMC ... 1. ...

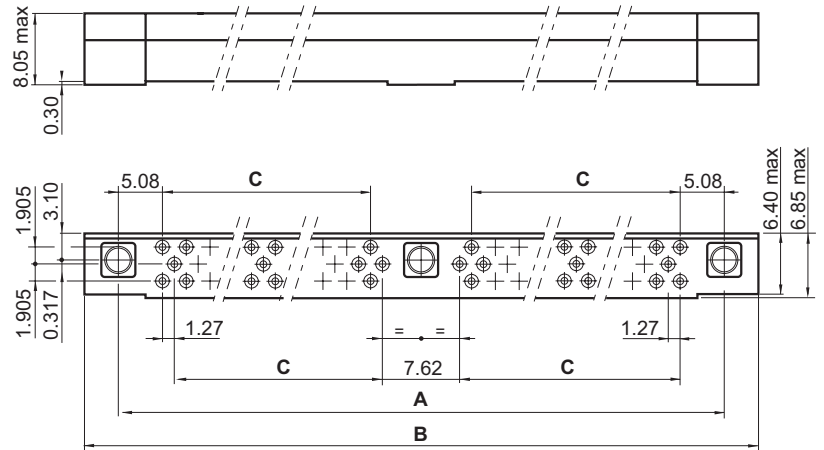
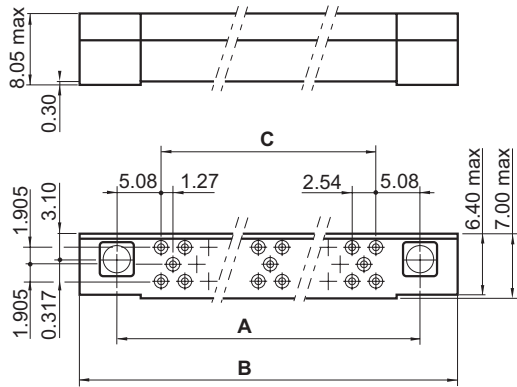

No. of contacts	26	44	62	80	98	144	162
A	30.48	45.72	60.96	76.20	91.44	137.16	152.40
B max	38.50	53.70	69.00	84.20	99.50	145.20	160.40
C	20.32	35.56	50.80	66.04	81.28	58.42	66.04

► MALE GUIDE STYLES

POLARISED TRANSVERSE MOUNT (moulding A)

Ref: **110** Ref: **110**

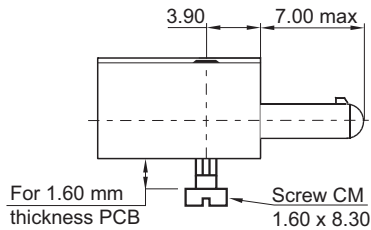

UNPOLARISED TRANSVERSE MOUNT (moulding A) CENTRAL GUIDE (KMC 144-162)

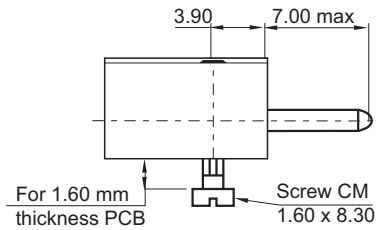

POLARISED VERTICAL MOUNT (moulding B)

Ref: **111** Ref: **112**

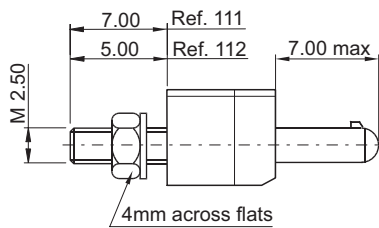

UNPOLARISED VERTICAL MOUNT (moulding B) CENTRAL GUIDE (KMC 144-162)

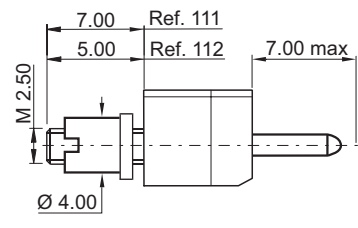

POLARISED VERTICAL FLOAT MOUNT (moulding B)

Ref: **113**

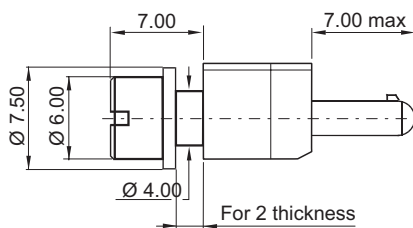

UNPOLARISED VERTICAL FLOAT MOUNT (moulding B) CENTRAL GUIDE (KMC 144-162)

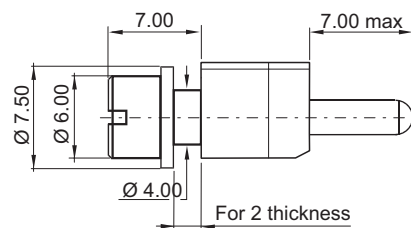

POLARISED VERTICAL FLOAT MOUNT (moulding B)

Ref: **128**

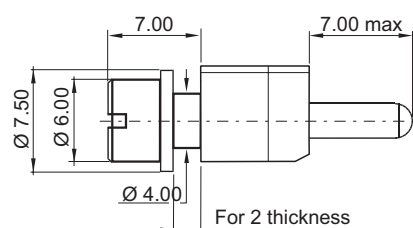

► MALE GUIDE STYLES

UNPOLARISED TRANSVERSE MOUNT (moulding A)

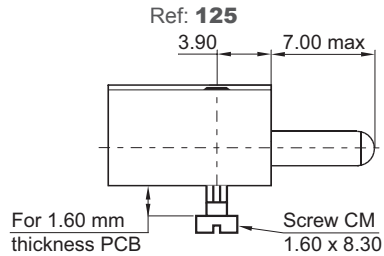

UNPOLARISED TRANSVERSE MOUNT (moulding A) CENTRAL GUIDE (KMC 144-162)

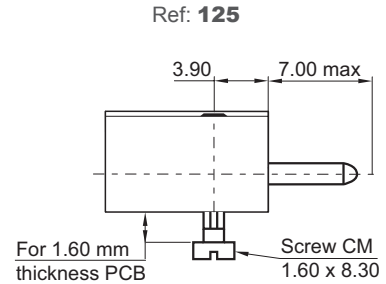

UNPOLARISED VERTICAL MOUNT (moulding B)

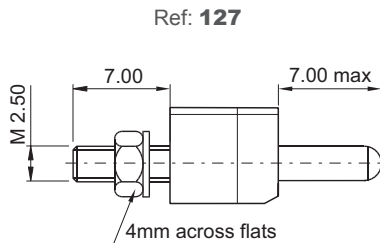

UNPOLARISED VERTICAL MOUNT (moulding B) CENTRAL GUIDE (KMC 144-162)

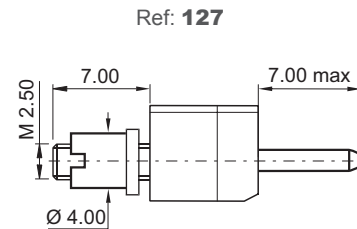

UNPOLARISED TRANSVERSE MOUNT (moulding B)

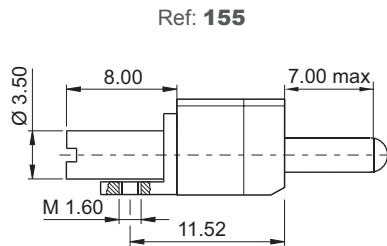

UNPOLARISED TRANSVERSE MOUNT (moulding B) CENTRAL GUIDE (KMC 144-162)

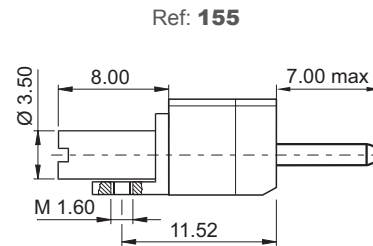

POLARISED TRANSVERSE MOUNT (moulding B)

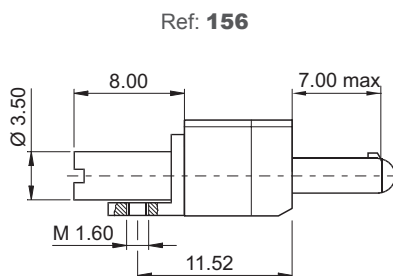

UNPOLARISED TRANSVERSE MOUNT (Moulding B) CENTRAL GUIDE (KMC 144-162)

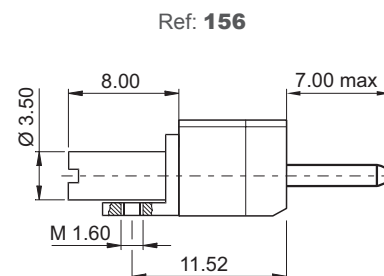

► FEMALE GUIDE STYLES

POLARISED VERTICAL MOUNT (moulding B)

Ref: 121 Ref: 143 Ref: 143

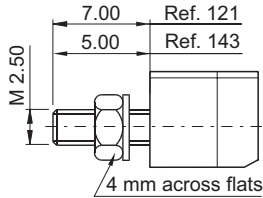

UNPOLARISED VERTICAL MOUNT (moulding B) CENTRAL GUIDE (KMC 144-162)

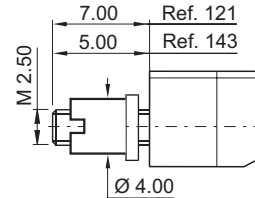

POLARISED TRANSVERSE MOUNT (moulding B)

Ref: 124

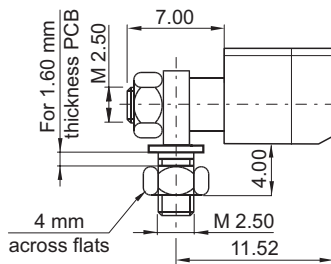

UNPOLARISED TRANSVERSE MOUNT (moulding B) CENTRAL GUIDE (KMC 144-162)

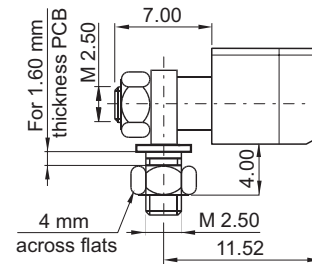

POLARISED VERTICAL FLOAT MOUNT (moulding B)

Ref: 123

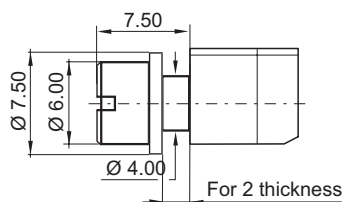

ALL KEYING TYPES (moulding B)

Ref: 130

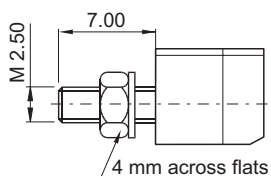

ALL KEYING TYPES (moulding B) CENTRAL GUIDE (KMC 144-162)

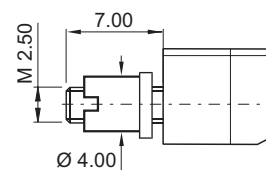

► FEMALE GUIDE STYLES

**ALL KEYING TYPES
(moulding B)**

Ref: **133**

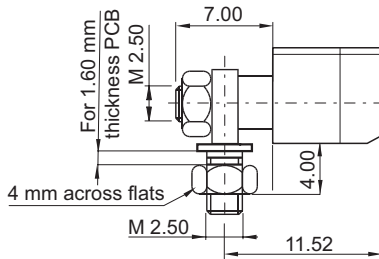

**ALL KEYING TYPES (moulding B)
CENTRAL GUIDE (KMC 144-162)**

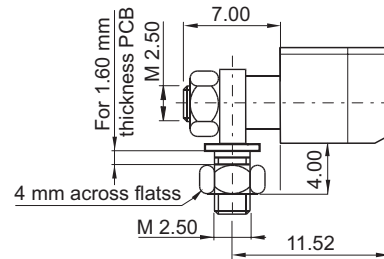

**ALL KEYING TYPES
(moulding B)**

Ref: **153**

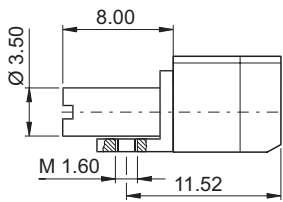

**ALL KEYING TYPES (moulding B)
CENTRAL GUIDE (KMC 144-162)**

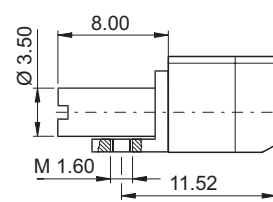

**POLARISED TRANSVERSE MOUNT
(moulding B)**

Ref: **154**

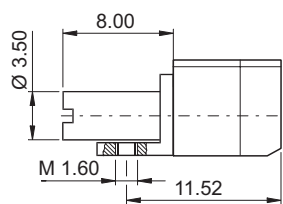

**UNPOLARISED TRANSVERSE MOUNT (moulding B)
CENTRAL GUIDE (KMC 144-162)**

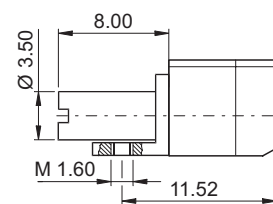

► GUIDE STYLES

FEMALE

UNPOLARISED TRANSVERSE MOUNT (moulding A)

Ref: 173

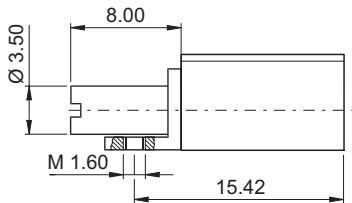

UNPOLARISED TRANSVERSE MOUNT (moulding A) CENTRAL GUIDE (KMC 144-162)

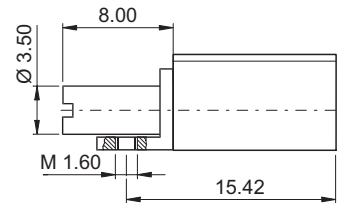

POLARISED TRANSVERSE MOUNT (moulding A)

Ref: 174

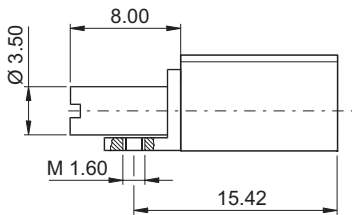

UNPOLARISED TRANSVERSE MOUNT (moulding A) CENTRAL GUIDE (KMC 144-162)

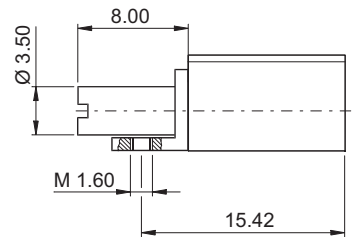

FEMALE

MASS AND POWER CONTACT (moulding B)

Ref: 190

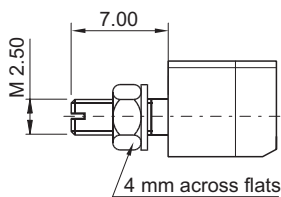

MALE

MASS AND POWER CONTACT (moulding A)

Ref: 191

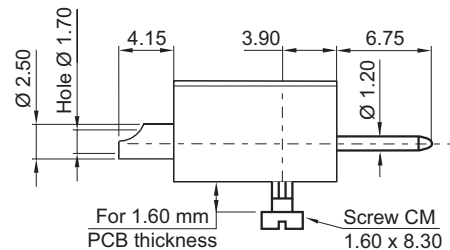

FEMALE - MALE

UNPOLARISED TRANSVERSE MOUNT (moulding B)

Ref: 703 Ref: 703

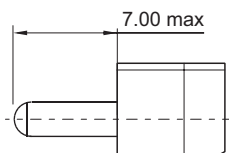

UNPOLARISED TRANSVERSE MOUNT (moulding B) CENTRAL GUIDE (KMC 144-162)

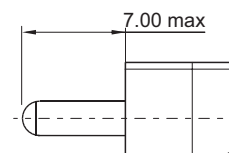

▶ LOCKING DEVICE COMPATIBILITY CHART

						A	Moulding
						B	
							206
							205
							201
					Male locking devices		
A	B				Female locking devices		
Moulding		204	203	202/207			

Compatible

NOTE: the connector must be fitted with its locking devices before soldering on the PCB (straight through board solder):

- ▶ Connector on PCB: impossibility to change the keying.
 - ▶ If you need to change the keying:
 - pierce PCB through Ø 3.70, fixing devices
 - use 054826.000R shouldered washer
- } (for 202 and 207)

▶ LOCKING STYLES

MALE

JACKSCREW, FREE CONNECTOR (moulding B)

Ref: **201** Ref:  **201**

For **KMC 144-162** the supplied central guide is Ref: **111**

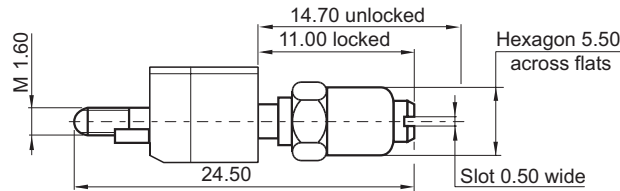

JACKSCREW, TRANSVERSE MOUNT (moulding A)

Ref: **205**

For **KMC 144-162** the supplied central guide is Ref: **110**

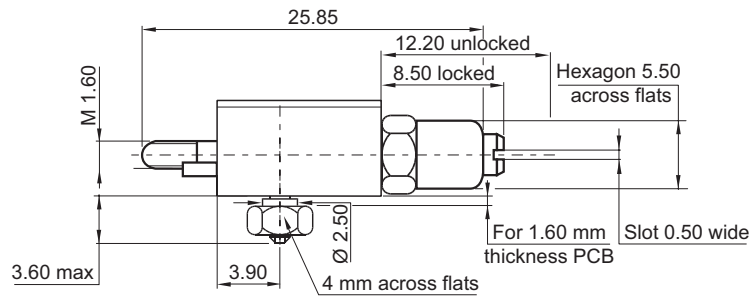

JACKSCREW, FREE CONNECTOR (moulding B)

Ref: **206** Ref:  **206**

For **KMC 144-162** the supplied central guide is Ref: **112**

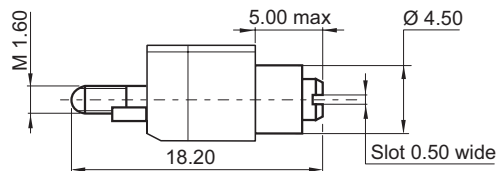

► LOCKING STYLES

FEMALE

NON ROTATING JACKSCREW, VERTICAL MOUNT (moulding B)

Ref: **202** Ref:  **202**

For **KMC 144-162** jackscrew 202 the supplied central guide is Ref: **121**

Ref: **207**

jackscrew 207 the supplied central guide is Ref: **143**

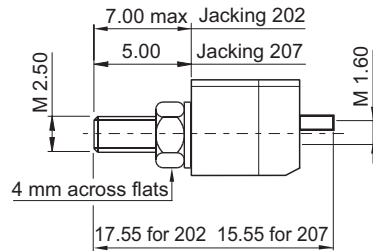

NON ROTATING JACKSCREW, TRANSVERSE MOUNT (moulding A)

Ref: **203**

For **KMC 144-162** jackscrew 202 the supplied central guide is Ref: **173**

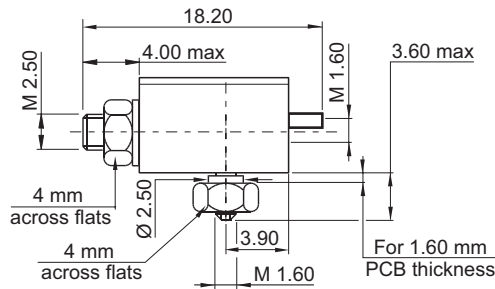

NON ROTATING JACKSCREW, TRANSVERSE MOUNT (moulding B)

Ref: **204** Ref:  **204**

For **KMC 144-162** the supplied central guide is Ref: **111**

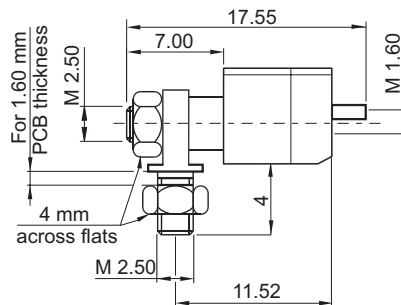

▶ MATING SIDE LAYOUT VIEW

MOULDING A

PLUG

RECEPTACLE

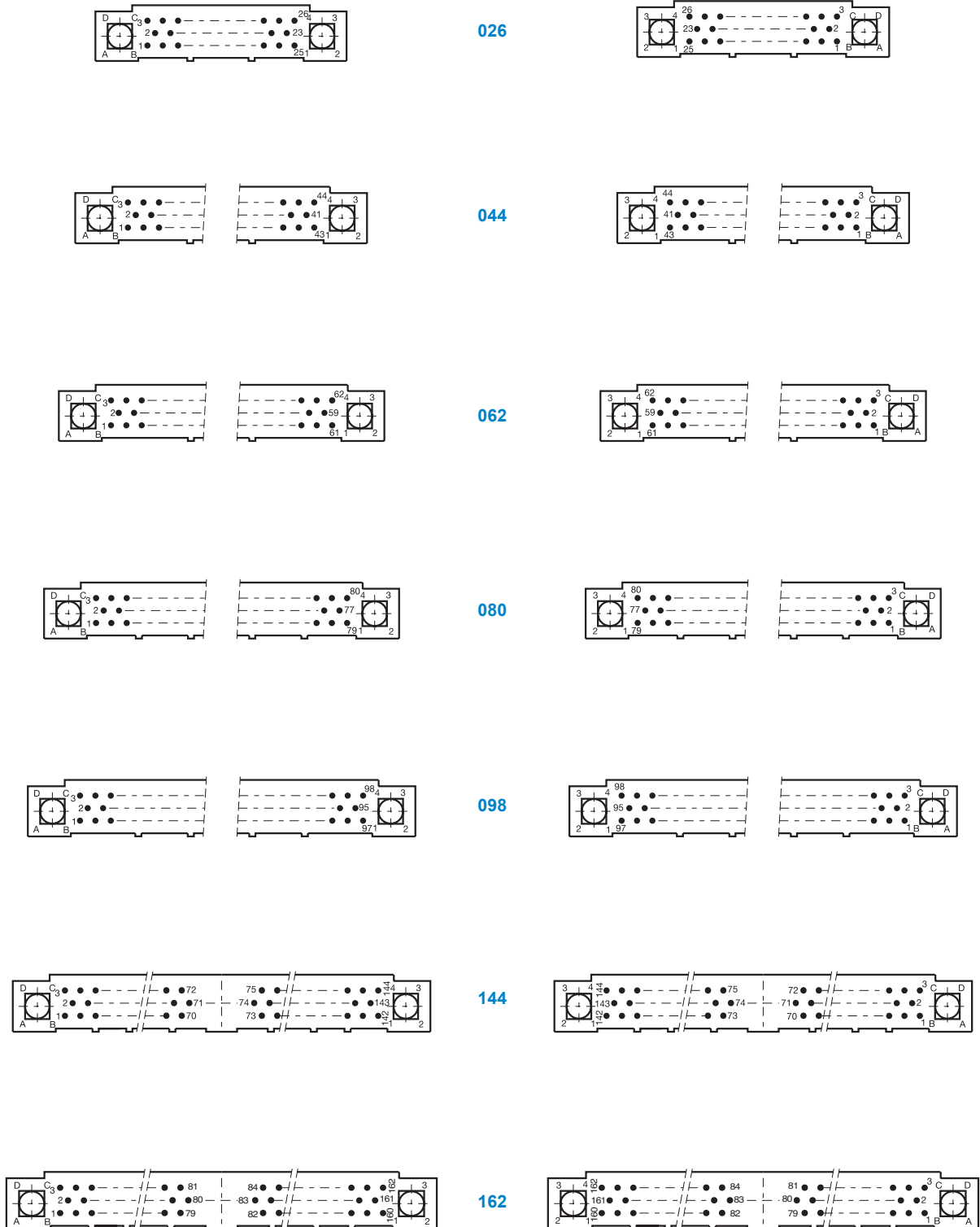

▶ MATING SIDE LAYOUT VIEW

MOULDING B

PLUG

RECEPTACLE

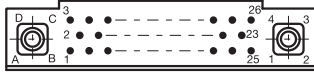

026

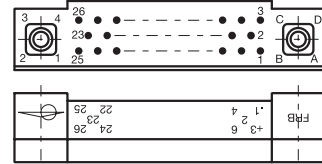

044

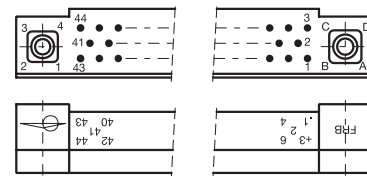

062

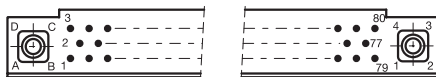
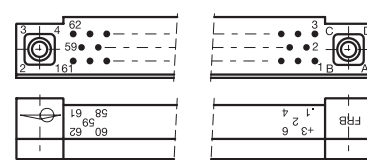

080

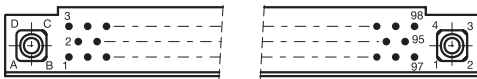
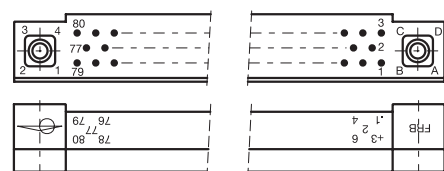

098

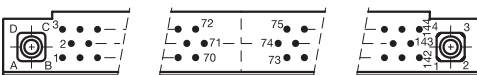
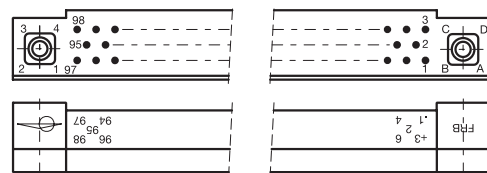

144

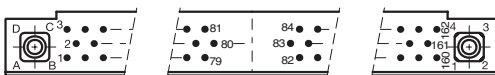
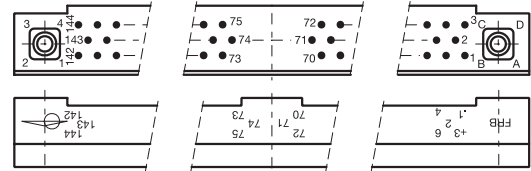

162

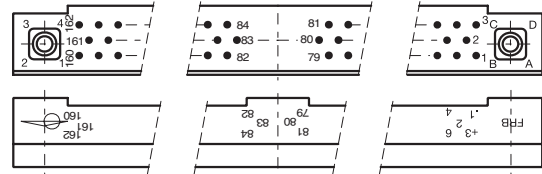

► BOARD PREPARATION DETAILS

TWO PARTS (moulding B)

26 TO 98 CONTACTS

144 TO 162 CONTACTS

MOTHER BOARD

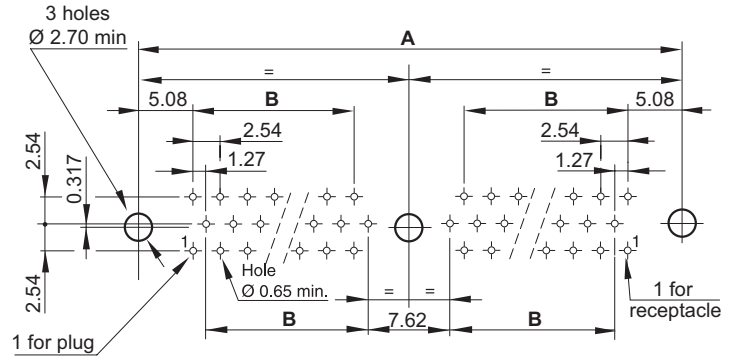
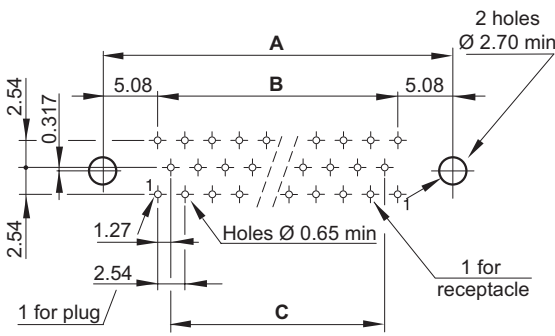

Female or male, plug or receptacle, straight solder terminations 30 or 31
 Guide styles: 111 - 112 - 121 - 127 - 130 - 143 - 190

DAUGHTER BOARD

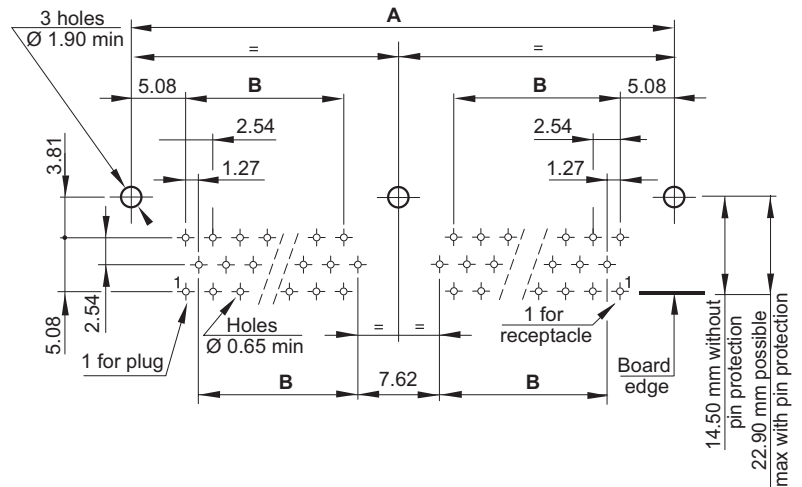
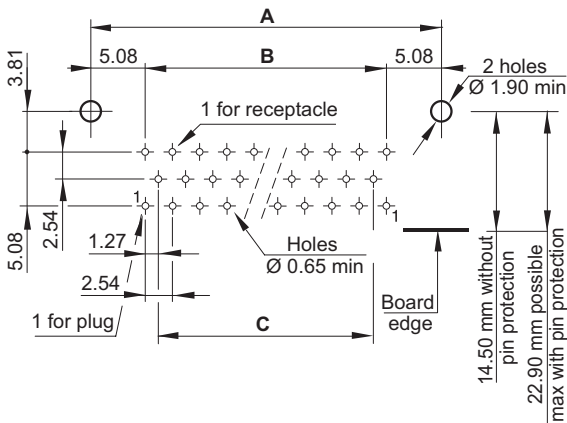

Female or male, plug or receptacle, 90° termination
 Guide styles: 153 - 154 - 155 - 156

No. of contacts	26	44	62	80	98	144	162
A	30.48	45.72	60.96	76.20	91.44	137.16	152.40
B	20.32	35.56	50.80	66.04	81.28	58.42	66.04
C	17.78	33.02	48.26	63.50	78.74	-	-

▶ BOARD PREPARATION DETAILS

TWO PARTS (moulding B)

26 TO 98 CONTACTS

144 TO 162 CONTACTS

DAUGHTER BOARD

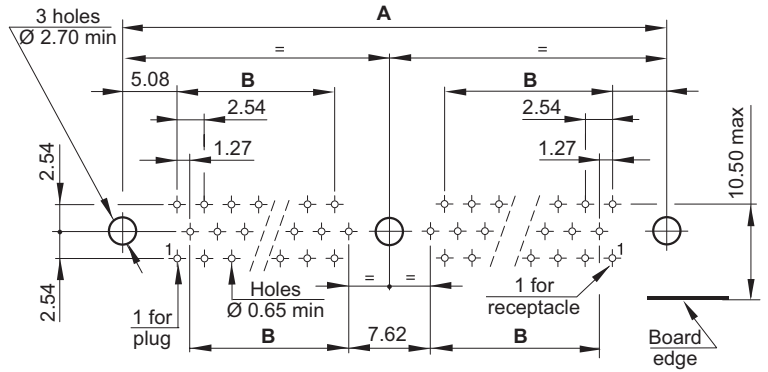
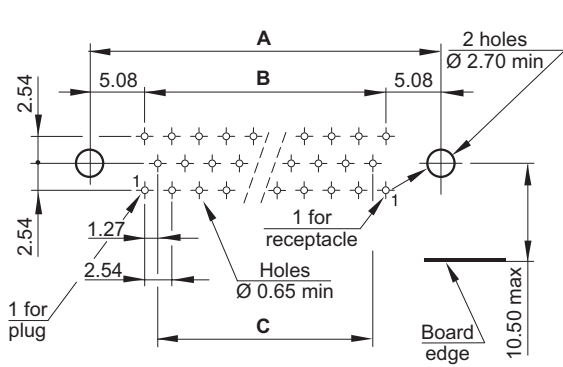

Female or male, plug or receptacle, 90° termination
Guide styles: 124 - 133

No. of contacts	26	44	62	80	98	144	162
A	30.48	45.72	60.96	76.20	91.44	137.16	152.40
B	20.32	35.56	50.80	66.04	81.28	58.42	66.04
C	17.78	33.02	48.26	63.50	78.74	-	-

► BOARD PREPARATION DETAILS

ONE PART (moulding A)

DAUGHTER BOARD

26 TO 98 CONTACTS

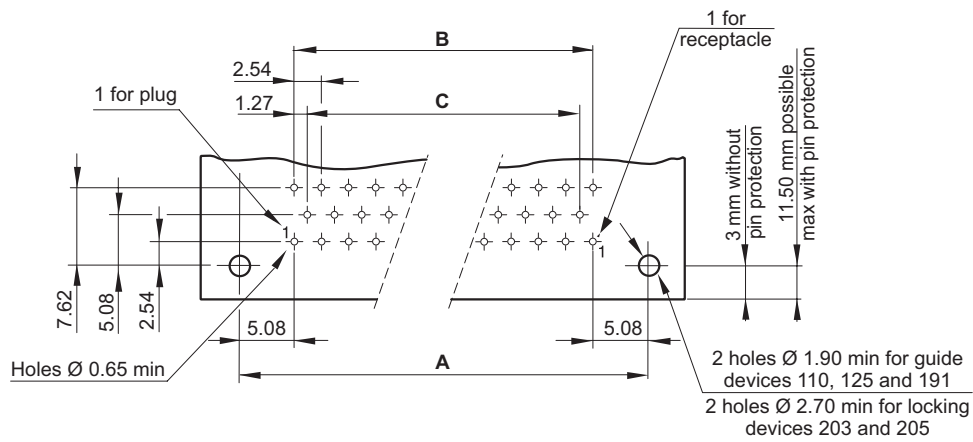

Male, plug or receptacle, 90° termination

Guide styles: 110 - 125 - 191 - 203 - 205

144 TO 162 CONTACTS

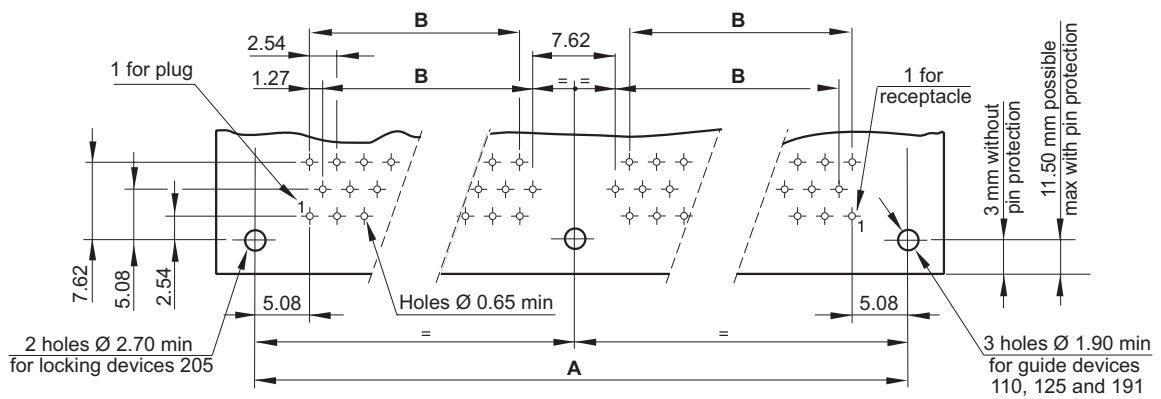

Male, plug or receptacle, 90° termination

Guide styles: 110 - 125 - 191 - 205

No. of contacts	26	44	62	80	98	144	162
A	30.48	45.72	60.96	76.20	91.44	137.16	152.40
B	20.32	35.56	50.80	66.04	81.28	58.42	66.04
C	17.78	33.02	48.26	63.50	78.74	-	-

▶ PANEL PREPARATION DETAILS

TWO PARTS (moulding B)

26 TO 98 CONTACTS

144 TO 162 CONTACTS

MOTHER BOARD

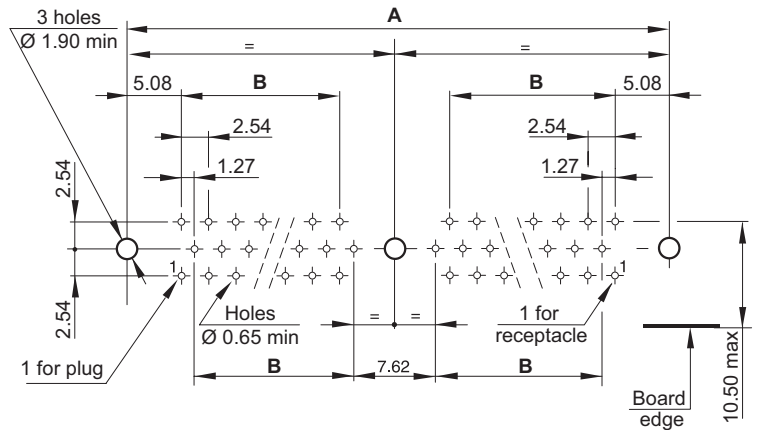
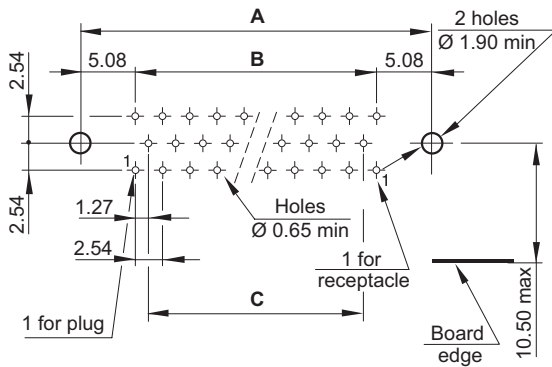

Plug or receptacle, 90° termination
Guide styles: 153 - 154 - 155 - 156

DAUGHTER BOARD

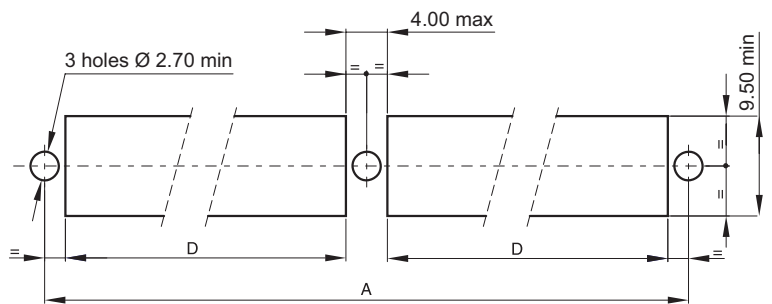
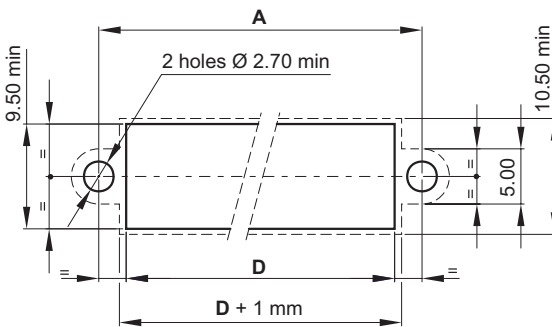

— Fixed mount - - - Float mount (2 mm thickness)

Female or male, plug or receptacle, 90° termination 40 - 50 - 51
Guide styles: 111 - 112 - 121 - 127 - 130 - 143 - 190 - (Fixed Mount)
Guide styles: 113 - 123 - 128 - (Float Mount)
Locking Styles: 202 - 207

No. of contacts	26	44	62	80	98	144	162
A	30.48	45.72	60.96	76.20	91.44	137.16	152.40
B	20.32	35.56	50.80	66.04	81.28	58.42	66.04
C	17.78	33.02	48.26	63.50	78.74	-	-
D	25.90	41.20	56.40	71.60	86.90	63.60	71.60

TECHNICAL CHARACTERISTICS

	SIGNAL CONTACT	POWER CONTACT	HIGH FREQUENCY CONTACT
Contact diameter	HC® Ø 0.50 mm	HC® Ø 2 mm	HE 807 type
Number of contact	Up to 162		
Pitch	1.905mm between rows 1.27mm between quicuncial contacts	5.08 on 1 row	
Rows	3		

ELECTRICAL

Current rating (at 25°C)	3 A max	15 A	0.5 A
Dielectric withstanding voltage	800 Vrms		
Nominal voltage	180 Vrms 50HZ		
Impedance	50Ω		
Contact resistance	≤ 8 mΩ	≤ 2 mΩ	≤ 10 mΩ
Insulation resistance	10 ⁴ mΩ (500 Vcc)	≥ 10 ⁷ MΩ	

ENVIRONMENTAL

Temperature range	-55° C + 125° C		
Mating forces	FI ≤ 8N - FS ≤ 3N	1N ≤ FI/FS ≤ 5N	
Conformity	NF C-UTE C 93-424		

MATERIALS & PLATINGS

Contact	Brass or bronze
Moulding	Glass fiber filled diallyl - Phtalate
Guides	Stainless steel or nickel plated brass
Pin body	Standard: 0.25 µm Gold / 1.27 µm Ni Space: 1.27 µm Gold / 1.27 µm Ni (min)
Socket body	Standard: 0.25 µm Gold / 1.27 µm Ni on activ area -1.27 µm Ni on non activ area Space: 0.25 µm Gold / 1.27 µm Ni (min)
Socket wires	Standard: 1 µm Gold / 0.20 µm Ni Space: 1.27 µm Gold / 0.20 µm Ni (min)

MECHANICAL

Mating & unmating cycle	5000
Guiding	By two outside guides (2 guiding styles) and one central guide (3 guidind styles)
Keying	By rotating of outside polarised guides (up to 16 keying)

Dimension are in mm

HOW TO ORDER



1 ▶ TYPE

A

H MOULDING WITH CAVITIES FOR SPECIAL CONTACTS

B

3 **6** NUMBER OF CAVITIES FOR SPECIAL CONTACTS

B

26 **44** **80** **90** **26** NUMBER OF SIGNAL CONTACTS 0.50 MM

2 ▶ MOULDING POLARITY

NF C-UTE C 93-424

SPACE GRADE

12	54	Female plug	1A	-	Tinned female plug**	26	46	Tinned female receptacle*
13	55	Male plug	1B	-	Tinned male plug**	27	47	Tinned male receptacle*
16	56	Tinned female plug*	22	44	Female receptacle	2A	-	Tinned female receptacle**
17	57	Tinned male plug*	23	45	Male receptacle	2B	-	Tinned male receptacle**

3 ▶ TERMINATION STYLES

(See KMC Ordering information p.43)

4 ▶ MOUNTING HARDWARE

GUIDE STYLES (see p. 50 to 54) - (Consult us for special guides) - See KMC ordering information p. 43

LOCKING STYLES (see p. 56-57) - See KMC ordering information p. 43

* For 90° & straight terminations (splicing on PCB)

** RoHS conform for 90° & straight terminations (splicing on PCB)

LAYOUT

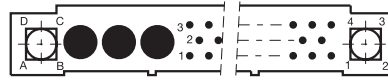

No. of fixings	KMH layout	No. of special contact cavities	No. of signal contacts
2	326	3	26
2	344	3	44
2	380	3	80
3	390	3	90

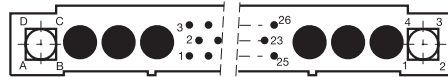

KMH layout	No. of special contact cavities	No. of signal contacts	KMH layout equivalent dimensions
			044
626	6	26	062
			098
			108

► DIMENSIONS

26 TO 80 SIGNAL CONTACTS & 3 SPECIAL CONTACT CAVITIES

One part plug (moulding A)
only KMH 380

Two parts plug & receptacle (moulding B)
KMH 326, 344, 380

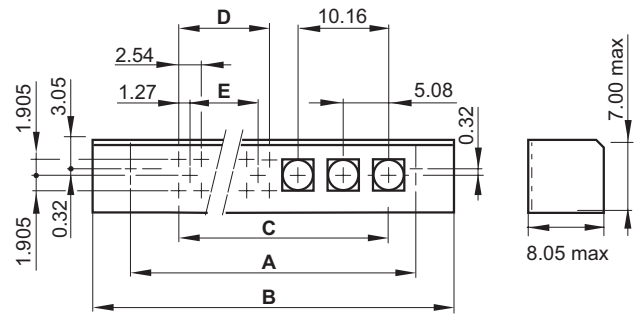
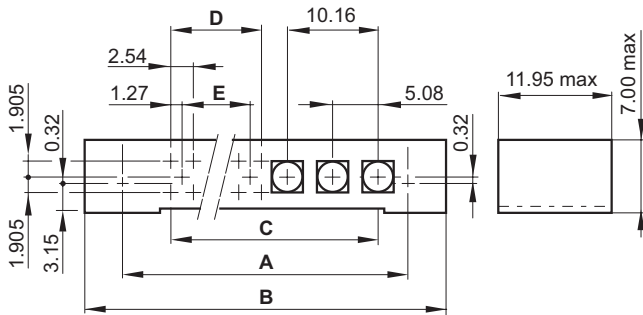

90 SIGNAL CONTACTS & 3 SPECIAL CONTACT CAVITIES

Two parts plug & receptacle (moulding B) KMH 390

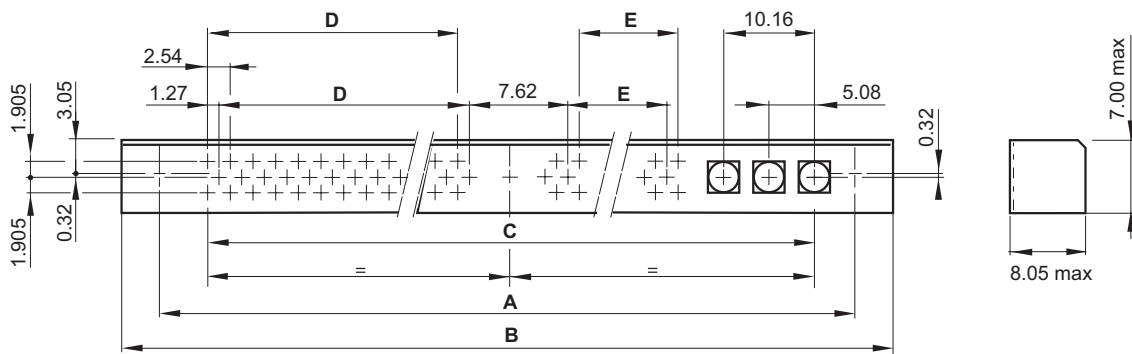

KMH layout	A	B max	C	D	E	KMH layout equivalent dimensions
326	45.72	53.70	35.56	20.32	17.78	044
344	60.96	69.00	50.80	35.56	33.02	062
380	91.44	99.50	81.28	66.04	63.50	098
390	106.68	114.70	96.52	43.18	27.94	108

26 SIGNAL CONTACTS & 6 SPECIAL CONTACT CAVITIES

Two parts plug & receptacle (moulding B) with special contact cavities on both extremities KMH 626

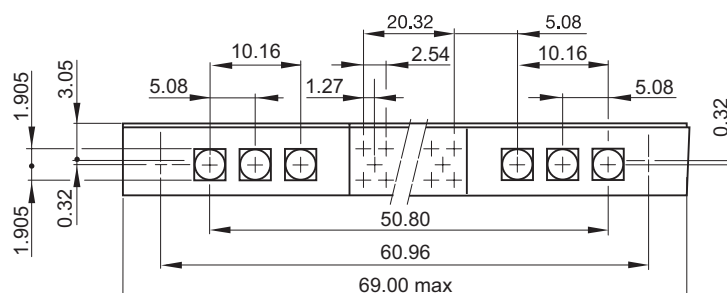

► POWER & HIGH FREQUENCY CONTACTS (NF C-UTE C 93-569)

EXAMPLE OF CONTACT OVERVIEW (020 084 2- 10R N1)

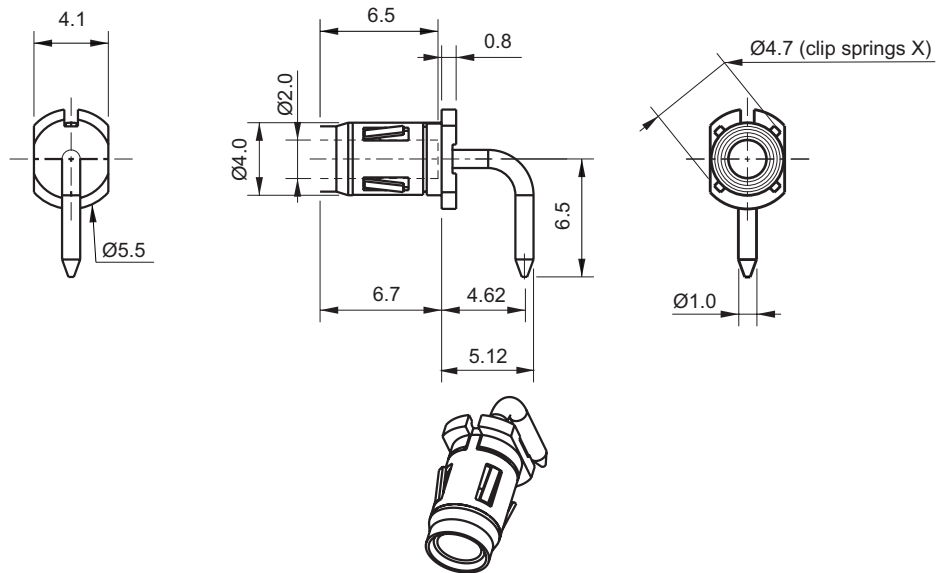

Male	P/N	Female	P/N
90° termination	020 085 1- 10R OG	90° termination	020 084 2- 10R G1
Straight termination	020 087 1- 30R OG	Straight termination	020 056 2- 30R G1
Solder bucket termination	020 091 1- 40R OG	Solder bucket termination	020 060 2- 40R G1

► COAXIAL CONTACTS

	Male P/N	Female P/N
Vertical mount, suitable for flexible cable Ø 1.9 max ref. KX 21 A (RG 178 B/U or RG 196)	KMX 3-M 081	KMX 3-F 081
Transverse mount, suitable for flexible cable Ø 1.9 max ref. KX 21 A (RG 178 B/U or RG 196) Usable with mother board, thickness 3.2 mm max	KMX 3-M 092	KMX 3-F 092
Vertical mount, suitable for flexible cable Ø 2.5 max ref. KX 22 A (RG 316)	KMX 3-M 101	KMX 3-F 101
Transverse mount, suitable for flexible cable Ø 2.5 max ref. KX 22 A (RG 316) Usable with mother board, thickness 3.2 mm max	KMX 3-M 112	KMX 3-F 112
Vertical mount, suitable to semi-rigid cable Ø 2.2 max ref. KS 1 A (RG 405 - UT 85)	KMX 3-M 131	KMX 3-F 131
Transverse mount, suitable to semi-rigid cable Ø 2.2 max ref. KS 1 A (RG 405 - UT 85) Usable with mother board, thickness 3.2 mm max	KMX 3-M 142	KMX 3-F 142
Straight tail termination for direct mount on to PCB	KMX 3-M 041	KMX 3-F 041
90° tail termination for direct mount on to PCB	KMX 3-M 032	KMX 3-F 032
SMT termination	KMX 3-M 172	KMX 3-F 172

▶ ACCESSORIES & TOOLS

SCREWDRIVERS

Reference	Use	Pinning			Remark
S_____028	- Connector fitted with female guides - "B" moulding - Cover's fixing screw for female guide	144	to	162	These three screwdrivers can be delivered in a same packing under the reference S_____036
S_____029	- Connector fitted with male guides - "B" moulding - Cover's fixing screw for female guide and screw central fixing on wiring side	144	to	162	
S_____033	- "B" moulding - Cover's fixing screws	026	to	162	

SPECIAL CONTACT EXTRACTION TOOL



SD.030 00 CX 003

PIN PROTECTOR

Reference	Use	Guide style
KMC..._____302* ↙ Pinning	KMC... 13..110-KMC...23..111 KMC ... 13..111	Polarised male guide
KMC..._____303* ↙ Pinning	KMC... 13..125	Unpolarised male guide
KMC..._____304* ↙ Pinning	KMC... 23..153	Unpolarised female guide
KMC..._____305* ↙ Pinning	KMC... 23..121 KMC... 23..154	Polarised female guide

* Antistatic material

Note: these 4 references are not available for the 162 contacts version

Disclaimer 2014

All of the information included in this catalogue is believed to be accurate at the time of printing. It is recommended, however, that users should independently evaluate the suitability of each product for their intended application and be sure that each product is properly installed, used and maintained to achieve desired results.

Smiths Connectors makes no warranties as to the accuracy or completeness of the information, and disclaims any liability regarding its use.

Smiths Connectors reserves the right to modify design and specifications, in order to improve quality, keep pace with technological development or meet specific production requirements.

No reproduction or use without express permission of editorial and pictorial content, in any manner.

SMITHS CONNECTORS PRODUCT LINES

PCB

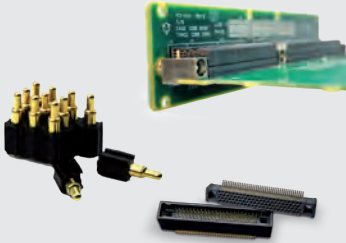

- ▶ Low, medium and high density board-to-board, cable to board and stacking
- ▶ Rugged standard
- ▶ Low profile
- ▶ Signal, power, coaxial & high speed configurations
- ▶ Spring probe connectors
- ▶ Mixed signal, power and coaxial contact connectors

POWER



- ▶ Circular
- ▶ Configurable rectangular
- ▶ Ruggedized
- ▶ Single and Multi-Way Connectors
- ▶ Power contact up to 1,200 Amps
- ▶ Excellent performance in harsh environment conditions
- ▶ Cable assembling

EMI/EMP FILTER

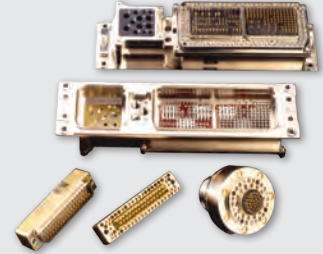

- ▶ EMI/RFI filtering and transient protection
- ▶ RoHS compliant solderless filter connectors available
- ▶ Circular, ARINC, D-Subminiature
- ▶ Filtered adapters for "bolt on" EMI solutions

MODULAR/RECTANGULAR



- ▶ Configurable with modules for signal, power, coax, fiber optics and/or pneumatics
- ▶ Easy configuration in a single frame
- ▶ For rack & panel, and cable applications
- ▶ Guided hardware for blind
- ▶ D-sub connectors
- ▶ Micro-D style
- ▶ Signal connectors for hand held and docking stations

CIRCULAR



- ▶ Crimp and solder terminations
 - ▶ Various types of cable clamps
 - ▶ Stamped hyperboloid contact
- MEDICAL**
- ▶ Plastic & Metal
 - ▶ Push Pull/Push-button latch mechanism

HEAVY DUTY



- ▶ Ultra reliable hyperboloid contact
- ▶ Modular solution: signal, power, data contacts, and fiber optics
- ▶ Up to 250A, coax 50 ohms
- ▶ Rugged aluminum shell
- ▶ High resistance in harsh environment
- ▶ EMC shielding
- ▶ Easy cable mounting

SPRING PROBES

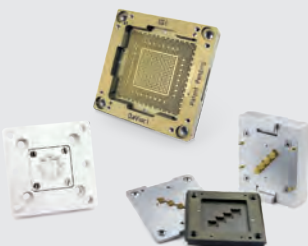

- ▶ Z-axis compliant
- ▶ Blind mate engagement
- ▶ Long cycle life
- ▶ High density
- ▶ Extreme miniaturization
- ▶ Printed circuit board test
- ▶ Bare board test
- ▶ Coaxial contacts

MIL/AERO STANDARD



- ▶ MIL and ARINC standards
- ▶ Rectangular, Circular, D-Sub and Rack and Panel Connectors
- ▶ Filter, Fiber optic, high speed, RF, and spring probe connectors

HIGH SPEED COPPER/FIBER

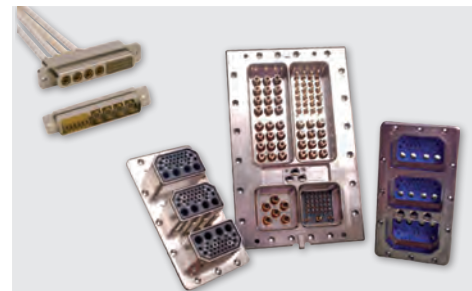

- ▶ Quadrx and Twinax Connectors
- ▶ Rugged D-Sub Connectors
- ▶ ARINC and MIL-STD Contacts
- ▶ Micro Twinax/Quadrx
- ▶ Butt-Joint and Expanded Beam Contacts
- ▶ ARINC 801 Termini
- ▶ Floating Fiber Termini



SMITHS CONNECTORS GLOBAL SUPPORT

AMERICAS

info.us@smithsconnectors.com

Costa Mesa, CA
1.714.371.1100

Hudson, MA
1.978.568.0451

Kansas City, KS
1.913.342.5544

EUROPE

France

33.2.32969176
info.fr@smithsconnectors.com

Germany

49.991.250.120
info.de@smithsconnectors.com

Italy

39.010.60361
info.it@smithsconnectors.com

United Kingdom

44.208.236.2400
info.uk@smithsconnectors.com

ASIA

asiainfo@smithsconnectors.com

Shanghai, China
86.21.3318.4650

Suzhou, China
86.512.6273.1188

Singapore
65.6846.1655

visit us at | smithsconnectors.com |     